

# The Practical Guide to Project Management

Christine Petersen, PMP



Download free books at

[bookboon.com](http://bookboon.com)

Christine Petersen, PMP

# The Practical Guide to Project Management

---

The Practical Guide to Project Management

1<sup>st</sup> edition

© 2013 Christine Petersen, PMP & [bookboon.com](http://bookboon.com)

ISBN 978-87-403-0524-1

# Contents

	<b>Preface</b>	<b>7</b>
<b>1</b>	<b>Introduction</b>	<b>8</b>
1.1	The Project Process	9
1.2	The Importance of a Project Management Process	9
1.3	Project Definition	10
1.4	Project Management Definition	11
<b>2</b>	<b>Initiation</b>	<b>12</b>
2.1	Project Criticality	12
2.2	Project Type (Complexity)	13
2.3	Scope Statement	14
2.4	SMART Objectives	16
2.5	Project Charter	16
2.6	Sponsors	19
2.7	Stakeholders	20
2.8	Requirements	22



## SÆT LYD PÅ FREMTIDEN

Widex udvikler højteknologiske høreapparater til gavn for de 500 millioner mennesker verden over, der har nedsat hørelse.

Mere end fem årtiers intensiv forskning og udvikling har gjort os til en af verdens førende høreapparatproducenter, og vi udvikler digital teknologi af en kvalitet, kun få kan måle sig med.

Som videnbaseret virksomhed betragter vi medarbejderne som vores vigtigste kapital. Vi kan godt lide at gøre tingene selv og sætter en ære i at være selvforsynende inden for de fleste områder. Det skaber et spændende, tværfagligt arbejdsmiljø med plads til initiativ og rig mulighed for personlig og faglig udvikling.

Vil du være med til at sætte lyd på fremtiden?  
Følg med i vores jobopslag på [www.widex.dk/job](http://www.widex.dk/job)  
eller skriv til [jobbox@widex.com](mailto:jobbox@widex.com)



[www.widex.com](http://www.widex.com)



<b>3</b>	<b>Project Planning</b>	<b>23</b>
3.1	Project Planning Checklist	24
3.2	Kick-Off Meeting	26
3.3	Work Breakdown Structure	27
3.4	Network Diagram	28
3.5	Gantt Chart	33
3.6	Managing Risks	34
3.7	Teams	37
<b>4</b>	<b>Execution</b>	<b>49</b>
4.1	Conflicts	49
4.2	Managing Changes in Projects	50
4.3	Resistance to Change	52
4.4	How to Influence Others?	56
<b>5</b>	<b>Control and Report</b>	<b>61</b>
5.1	Communication	62
5.2	Listening	71
5.3	Reporting	72

## Do you know Schneider Electric?

We are a global specialist in energy management represented in more than 100 countries. We provide technology and integrated solutions to optimise energy usage across multiple market segments. We are more than 130,000 colleagues worldwide and 1.000 of us are situated in Denmark.

We invest in our employees, in the environment and in the future. Each year 5% of our revenue is allocated for research and development activities. In Schneider Electric you have many career paths to choose from – also internationally.

Would you like take on the challenge of transforming  
the way people and organisations use energy?



Meet us at:  
[www.schneider-electric.dk/job](http://www.schneider-electric.dk/job)

**Schneider**  
**Electric**



5.4	Managing Delays	75
5.5	Escalation	75
5.6	Negotiating Rational Delays	76
5.7	Team Meetings	76
<b>6</b>	<b>Project or Phase Close</b>	<b>77</b>
<b>7</b>	<b>References</b>	<b>80</b>



# HD – vejen til en karriere i erhvervslivet

## LÆS HD I ØKONOMI OG LEDELSE

HD er en anerkendt diplom-uddannelse, som giver dig mulighed for at specialisere dig inden for det erhvervsøkonomiske fagområde ved siden af dit job.

### Læs mere

Aarhus: [hd.au.dk](http://hd.au.dk)

Herning: [auhe.au.dk/hd](http://auhe.au.dk/hd)



# Preface

This book is designed to help you understand the theory, tools, techniques and key success factors for you to succeed in your projects.

We will be looking at all aspects of managing projects – from the technical checklists to the soft skills that are essential for a Project Manager to succeed.

Christine Petersen, PMP, the founder and Director of the international specialist training, coaching and consulting company VIRAK, is the author of this book. Christine has been managing projects in Europe since 1990, and founded VIRAK in 2002 in order to provide solid, practical training courses, coaching and consulting to companies that need and use Project Managers, and in particular to concentrate on the human side of projects. Many books and courses have been written that are geared towards the technical side of Project Management, but Christine realized through her experiences that without strong team management and leadership as well as thorough management of people's reactions to change, projects have a high possibility of failure. She understood clearly the high cost to companies that project failure entails when the Project Managers are given their role by chance and without training and experience in the process of managing projects. Christine is often invited to speak at conferences, and has published several articles on-line and in print.

VIRAK is specialised in providing coaching, consulting and training in Project Management (they are one of the leading providers of a PMI® Project Management Professional Certification Preparation course in Switzerland) as well as in all the Soft Skills that enable people to work more efficiently and effectively – and with less stress.

Contact VIRAK:

Online: [www.virak.com](http://www.virak.com)

Email: [info@virak.com](mailto:info@virak.com)

Phone: +41 78 854 24 68

# 1 Introduction

This is the Project Management process that we will be using to manage our projects. It is based on the PMI® (Project Management Institute) processes and terminology as found in the PMBOK® (Project Management Body of Knowledge).

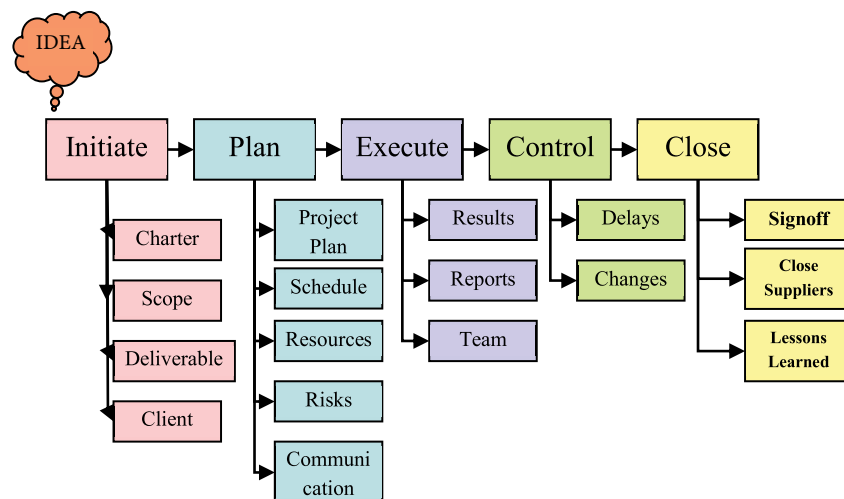

**Figure 1:** Project Management Process

The 5 stages of a project are: Initiate, Plan, Execute, Monitor and Control, and Close.

Below every stage you see the main outputs. These are the main deliverables to be done at each stage. There are other, minor deliverables that we will discuss in this book.

Even if you deliver nothing else except for these deliverables, your project will have a much greater chance for success.

**Success Factor:** Use a checklist to make sure you do not forget any steps



## 1.1 The Project Process

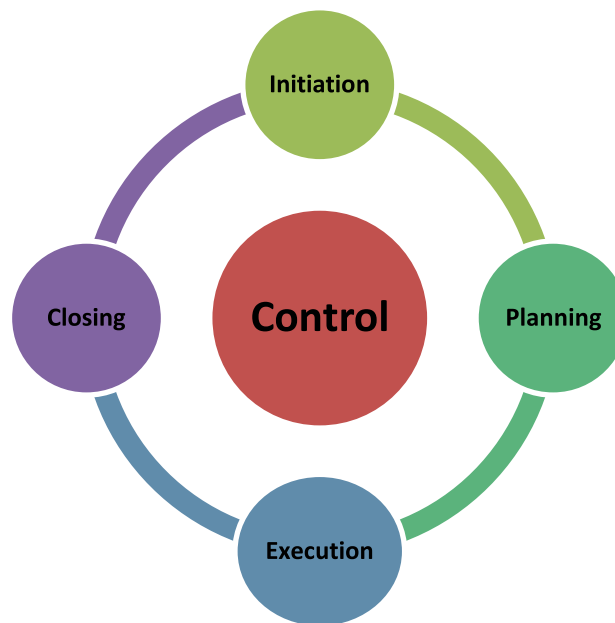

**Figure 2:** The Project Process

This is the Project Process using the PMBOK® terminology. It shows that “Planning” and “Executing” are not discrete processes but continue throughout the life of the project, from beginning to end.

It also shows that “Control” takes place continuously throughout the project.

## 1.2 The Importance of a Project Management Process

Projects are becoming more and more common in companies, and expectations are higher and higher in terms of performance (time, cost, specifications).

It is therefore important to have a project process in place that helps us achieve the expectations that the organisation places on us.

Projects are always tight on time and budget. The trick is to know how to balance these, together with the element of quality, to achieve a successful result.

We want a result where our customers are happy and want to work with us again.

We want a result where the team is motivated, and want to work with us again.

We want an effective process in place – not too light, not too heavy. Just enough to support us without blocking us with administration.

**Visible and sponsored:** Your role as Project Manager is also that of a salesperson. You have to continuously sell your project, or people will forget it exists and then not give it the priorities it needs. Your project needs a Sponsor – someone high enough in the organisation to be able to help you solve problems and clear the path when you cannot do it yourself. Someone who has political weight in the company.

**Repeatable:** The more you can repeat a process, the better you will become at using the process. This is like learning to ride a bicycle. The first time you use the process, it will feel strange and difficult, but once you have used it a couple of times, it will become a habit, and you will be able to save time and energy, and have more chance of success.

**Measurable:** To improve, we need to be able to measure. If you cannot measure the project progress, then you will not know if you are doing it right, or well enough. So, having a process in place, you can measure its effectiveness, and this can help you continuously improve your performance.

**Predictable:** A good Project Manager has a very long sight. He needs to see far ahead in order to see the obstacles (or risks) coming, and act to avoid hitting them. With a good process in place, we know what is coming up, and can spend more time being pro-active rather than re-active. This saves time that you can then spend dealing with the real unexpected issues that come up.

**Success Factor:** With a good process in place, we know what is coming up, and can spend more time being pro-active rather than re-active.

### 1.3 Project Definition

A **Project** is defined as:

- A temporary endeavour undertaken to create a unique product or service.
- It is often organized under the direction of a Project Manager, who will ensure that the project achieves its objectives.

A **Program** is defined as:

- A group of projects managed in a coordinated way.

These are the definitions according to the PMBOK®.

Note the key words: **Temporary** and **Unique**.

The title of Project Manager can be substituted by

- Project Director
- Project Coordinator
- Project Chief
- Project Lead
- Etc.

It is not important what the title is. It is important that the Project Manager knows that their role is to coordinate the team's work to achieve the required objectives in the time required with the budget required.

## 1.4 Project Management Definition

The application of:

- knowledge
- skills
- tools
- techniques

to project activities to meet the project requirements

The only thing that you cannot learn is "Experience". That takes time.

**Success Factor:** Learn as much as you can from others, and make sure you know what a Project Manager should do

## 2 Initiation

In the Initiation phase, the project is analysed, and first you have to decide whether to actually do the project.

The **main outputs** are:

Project Mission – why?

Project Objectives – what do we want to achieve?

Project Deliverables – the steps we need to achieve our objectives

Project Stakeholders – who has an interest in our project or result?

### 2.1 Project Criticality

It is important for the Project Manager and the Sponsor to have analysed the project and understood the **CRITICALITY** of the project in terms of the company.

**IFRS 2012**  
– nu også som e-bog

IFRS 2012, Standarder og fortolkningsbidrag – på dansk fås nu både som trykt bog samt som e-bog til smartphone, tablet og pc.

Introduktionspris: e-bog og trykt bog kr. 1545,-

 E-bog inkl. opdateringer i 2012

Læs mere og køb e-bogen sammen med den trykte bog her:  
[shop.magnus.dk](http://shop.magnus.dk)

**REGNSKAB**

**– Nu også som e-bog**

Magnus Informatik  
a Wolters Kluwer business

Download free eBooks at [bookboon.com](http://bookboon.com)

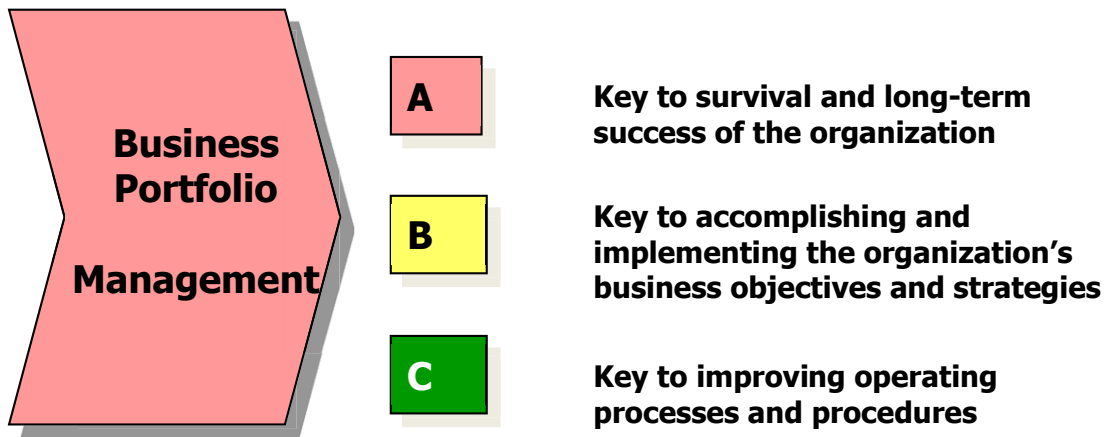

Figure 3: Project Criticality

Not all projects are equally critical, or equally important to the survival of the company.

## 2.2 Project Type (Complexity)

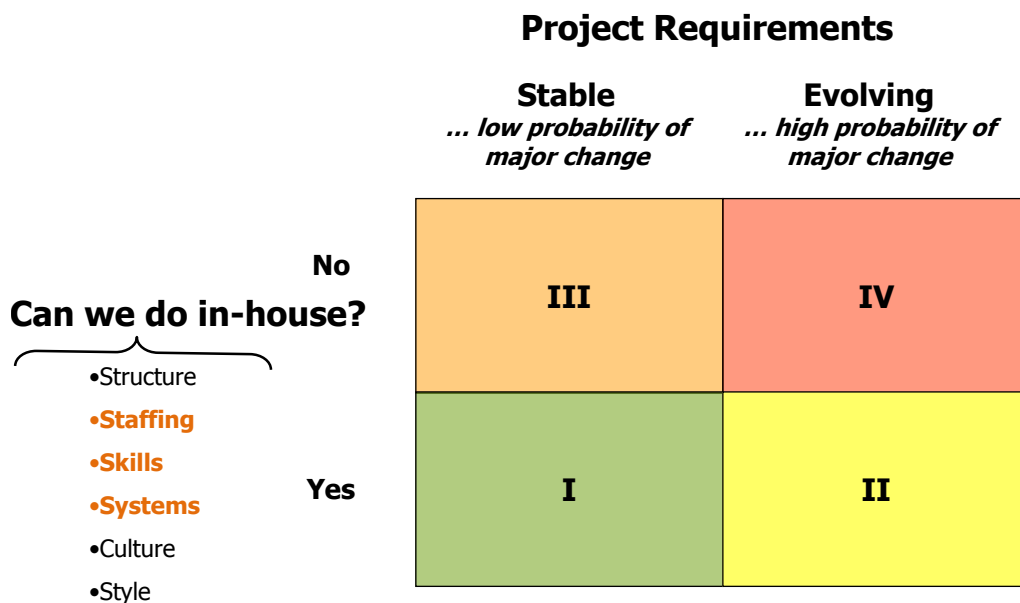

Figure 4: Project Type

It is equally important for the Project Manager and Sponsor to have understood the TYPE of project that they are dealing with since not all projects are the same.

### 2.2.1 Challenge to Capability:

**LOW** – We have the skills, staff and systems IN-HOUSE to do the project.

**HIGH** – we do not have the skills, staff or systems in-house, and need to find them outside the company.

### 2.2.2 Project Requirements:

**STABLE** – we can know the customer requirements and they remain more or less stable through the project.

**EVOLVING** – The project is to develop or create something totally new that we've never done before, so we have little idea of our requirements from the beginning, and they change and evolve as we go through the project.

**Success Factor:** Not all projects are the same. It is important to agree on each project's criticality and complexity.

## 2.3 Scope Statement

- Creates a sentence (or two) that answers the following questions:
- What?
- Why?
- When?
- Who?
- How much?
- Where?
- How many?
- How do we know we achieved our goals?
- What is OUT OF SCOPE??

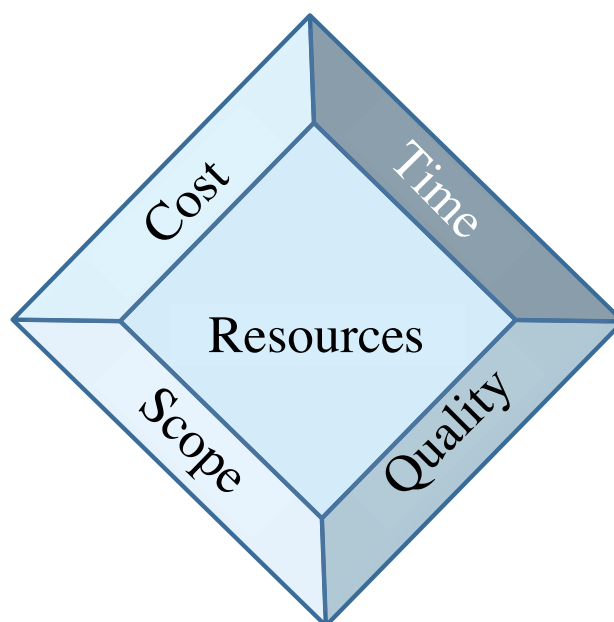

**Figure 5:** Competing Constraints

In any project, it is important that we can communicate what it is about. People will ask questions about it, or simply need to know what we are doing.

The 7 questions above are the most common questions people ask, so if you can answer them in advance, and create one or 2 sentences with the answers, then you will not need to keep answering the same questions again and again.

This also helps your team, your sponsor, your customer, and yourself understand more about the project.

The question “How Many?” may not need to be asked, if there is only one project result.

It is crucial to have defined how we know we have achieved our goals. If we do not know whether we have achieved our project goals, then we will not know whether our project was a success.

It is also crucial to define what is **OUT of Scope**. This avoids a lot of Scope Creep later on, as you can then simply refer back to the Scope Statement when people want to add scope to your project.

# Dine **fordele** ved forsikring hos **Pantaenius**



**Hjælp ved uheld**  
Du har behov for bugsering til nærmeste værft?  
Pantaenius overtager omkostningerne dog begrænset op til DKK 37.500,00!



**Inspektionsomkostninger**  
Du har haft en grundstødning og vil have bunden inspiceret?  
Pantaenius dækker inspektionen uden selvrisiko!



**Kontakt os**  
Har du spørgsmål til dine forsikringer?  
Du kan ringe +45-9751 33 88 eller skrive til os på e-mail [info@pantaenius.dk](mailto:info@pantaenius.dk)



**Ingen selvrisiko**  
Indbrud, transportskade, brand, lynnedslag eller totalskade?  
Ved disse skadesårsager er der ingen selvrisiko hos Pantaenius!

Østerbro 11 · 7800 Skive  
Tel. +45-9751 3388 · [info@pantaenius.dk](mailto:info@pantaenius.dk)  
[www.pantaenius.dk](http://www.pantaenius.dk)



**PANTAENIUS**  
Agentur for Lystfartøjsforsikring

DEN1003 www.hjphude 01/2012

As you can see, once we have answered the questions and created our Scope Statement, we will have filled our Competing Constraints triangle.

**Success Factor:** Know as much about your project's Competing Constraints as possible BEFORE you start to work. Agree on the Scope Statement with the team.

## 2.4 SMART Objectives

Once the Scope Statement has been defined, please apply the SMART evaluation to it.

**Specific** – Does it address a real business problem?

**Measurable** -Are we able to measure the problem, establish a baseline, and set targets for improvement?

**Attainable** – Is the goal achievable? Is the project completion date realistic?

**Relevant** – Does it relate to a business objective?

**Time Bound** – Have we set a date for completion?

## 2.5 Project Charter

The Charter is a document. It should not be too long, but concise, easy to read, and to the point. It should be signed by the Sponsor (or customer) and the Project Manager. It is created at the very start of the project.

It is written by the Sponsor and the Project Manager and is in essence a contract between them.

If your project is for an external client, then the Charter may well be the Supplier Contract.

**Project title and description** – keep it short and in language that everyone can understand

**Project Manager Assigned and Authority Level** – it is important that it be clear who the Project Manager is from the start of the project, and what his authority level is: what are the limits for signing and for decisions concerning the project?

**Business Case** – WHY are we doing this project? How will the result help the company?



**Scope Statement (including objectives)** – As above.

**Product description / deliverables** – What does the end result look like? What will we need to deliver in order to provide the end result?

**High level Risks** – already at this early stage, it is important to have thought about the risks of success or failure. If there are too many risks or if they are unacceptable, it is better to stop the project early on, before too much time and resources have been wasted.

**High level Constraints and Assumptions** – Constrains are restrictions or limitations. Assumptions are factors that we believe to be true until proven different.

**Signed and approved by...** – The Sponsor or Customer. It is important for the Charter to be signed, as it will then be taken more seriously.

**Success Factor:** Be sure to write the Charter together with your Sponsor, so that they are aware of and agree to the terms of the project.

**An example of a Project Charter**

<b>Project Name</b>		<b>Project Code</b>	
<b>Start Date</b>		<b>End Date</b>	
<b>Sponsor</b>	<b>Team Members</b>		
•	•	•	•
<b>Project Manager</b>	•	•	•
•	•	•	•
<b>Support</b>	•	•	•
•	•	•	•
<b>Goals and Objectives</b>	<b>Scope</b>		
• A	• A	• B	• C
• B	• B	• C	
• C	• C		
<b>Approach</b>			
• A			
• B			
• C			
<b>Milestones</b>	<b>Dependencies/Related Projects</b>		
• A	• A	• B	• C
• B	• B		
• C	• C		
<b>Deliverable</b>	<b>Completion Criteria</b>		
Deliverable A	Completion Criteria for A		
Deliverable B	Completion Criteria for B		
Deliverable C	Completion Criteria for C		
<b>Assumptions</b>			
• A			
• B			
• C			
<b>Risks and Issues</b>			
• A			
• B			
• C			
<b>Signed by</b>			
Sponsor:	Date:		
Project Manager:	Date:		

**Figure 6:** Project Charter

## 2.6 Sponsors

The Golden Rule states that if you have no Sponsor then you should not continue with the project. In reality, this may not always be true. However, be aware of the risks involved in not having a Sponsor or having a Sponsor who is either not active or does not know his/her role. It may also not be possible in reality to define the whole team at this early stage. It is important to define those team members you can, and start to bring their understanding up to the same level as your own.

### Sponsor – Project Manager Checklist

<b>Initiation Phase</b>	
<input type="checkbox"/>	There is one clearly identified Sponsor
<input type="checkbox"/>	The PM understands what the Sponsor expects
<input type="checkbox"/>	The problem or reason for the project has been clearly documented
<input type="checkbox"/>	The Project Content, what is IN and OUT OF Scope has been clearly documented
<input type="checkbox"/>	Project Specifications have been clearly identified and documented (in terms of numbers, time, etc.)
<input type="checkbox"/>	The budget and the Project deadline have been documented
<input type="checkbox"/>	The Sponsor has signed the Charter (comprising the above information)
<b>Planning Phase</b>	
<input type="checkbox"/>	The main project risks have been clearly documented
<input type="checkbox"/>	The constraints and assumptions have been clearly documented
<input type="checkbox"/>	The Project Stakeholders have been identified, analyzed and documented
<input type="checkbox"/>	The list of Suppliers has been documented
<input type="checkbox"/>	The Roles and Responsibilities Matrix (RAM) has been documented
<input type="checkbox"/>	The Milestones have been identified and documented
<input type="checkbox"/>	The Authority Level of the Project Manager has been documented
<input type="checkbox"/>	The Sponsor has signed the Project Plan (comprising the above information)
<b>Execution Phase</b>	
<input type="checkbox"/>	Agree with the Sponsor how often they wish to be informed and in what format
<input type="checkbox"/>	Communicate to the Sponsor appropriately (see above)
<input type="checkbox"/>	Immediately let the Sponsor know of any changes to the Triple Constraints : Time, Cost, Scope, Quality, Resources
<input type="checkbox"/>	Get Sponsor Signature on all changes that affect the Triple Constraints
<b>Closure Phase</b>	
<input type="checkbox"/>	Get Sponsor Signature at the end of every phase
<input type="checkbox"/>	Get Sponsor Signature at the end of the Project
<input type="checkbox"/>	File all documents relevant to the project at the end of the project

**Success Factor:** Ensure that you have a meeting with your Sponsor at the start of the project to define roles and responsibilities and expectations.

## 2.7 Stakeholders

### Anyone

- Affected by activities or results of a project
- Who can influence, support or resist the outcome
- With a personal, financial or professional interest in the outcome

### Failure to address stakeholder issues often leads to project “failure”!

One of the critical factors for success of a project is to have spent time on defining the stakeholders. If you do not identify all the stakeholders then those whom you have forgotten will be the ones who will cause you problems later on.

You will see that the list of stakeholders is a lot longer than you would expect. This is fine. It is important to build this list, and add to it as the project moves on in time.



**Assistance**  
Personalservice med kvalitet

### Træt af 100-vis af ansøgninger?

Lad Assistance Personaleservice a/s hjælpe dig næste gang du skal ansætte en ny medarbejder. Et rekrutteringssamarbejde med Assistance sikrer virksomheden:

- En ressourcebesparelse på 50-70 timer
- Et kompetent og etisk ansættelsesforløb
- En professionel sparring
- Garantiperiode – op til 6 måneder

Kontakt os for et uforpligtende møde på telefon 33 55 00 90



One easy way to define your stakeholders is to work with your team in a brainstorming session, using post-its.

It is important not to filter out any of the stakeholders, but to include them all. We first have to analyse the stakeholders before we know whether we can filter them out.

The Stakeholder Assessment Grid then allows us to analyse the Stakeholders.

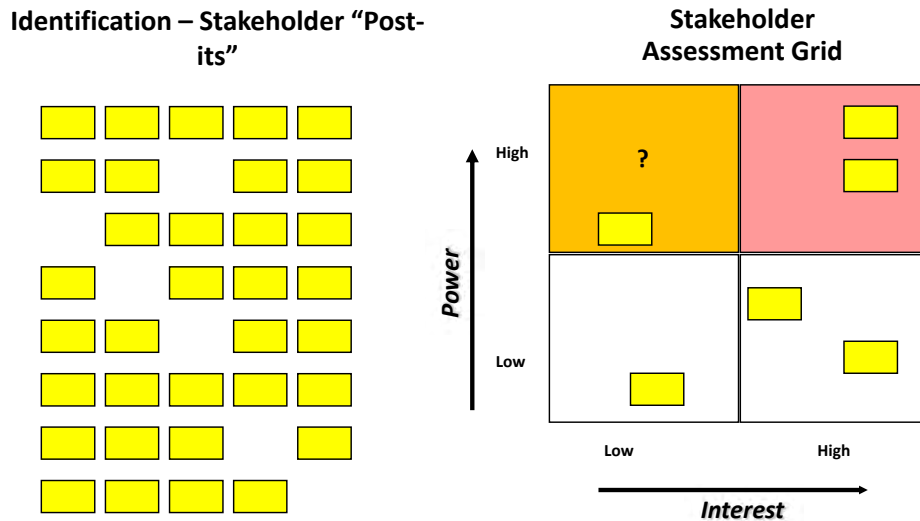

Figure 7: Stakeholder Analysis

- **Power:** The ability to contribute or withhold resources and/or to accept or reject outcomes.
- **Concern:** Affected by technical and social impacts and perceptions.

Once we have placed each stakeholder in the relevant box, we then must decide whether the stakeholder is a:

- **Proponent** (Is the stakeholder FOR the project?)
- **Resistor** (Is the stakeholder AGAINST the project?)

**Success Factor:** Don't forget any stakeholders. Know who is for and against the project – work actively to influence those that are against. Keep stakeholders involved.

## 2.8 Requirements

Now that we know who our Stakeholders are, it is time to understand what their requirements are.

What are their **NEEDS** and **WANTS** for this project?

What is the difference?

In real life, it is important to go and talk with the Stakeholders to understand their point of view, and get a dialogue going. Many stakeholders become resistors because nobody took the time to listen to them.

A deliverable for this step can also be called a “User Requirements Document”, or a “Requirements List” or similar.

Once we have defined the requirements, a useful exercise for the team to do is to analyse the requirements in terms of **DIFFICULTY** in achieving this requirement and the **IMPORTANCE** the requirement will have on the success of the project.

You can then number the stakeholders, and place the Stakeholder number on the requirement that they are expecting.

This is a good exercise since it allows us to be sure to have listed the requirements of all our Stakeholders (we have not forgotten anyone), and make sure that each requirement belongs to a Stakeholder.

**Success Factor:** If you don't know your stakeholders' requirements, you will never be able to meet them. Ask questions from the start.

# 3 Project Planning

Now that we have analysed our project in more detail, and understood the type of project, its criticality, the stakeholders, the Sponsor, and the requirements, we are ready to start planning the project.

The Project Management Plan describes **HOW** I plan to manage the changes to:

- Scope
- Time
- Cost
- Issues
- Risk
- Quality
- Communication
- Resources

It is a procedure or a set of procedures. Once defined, it can be used again in other projects.

It describes the steps that will be taken, who will take them, when, and how.

**See the light!**  
**The sooner you realize we are right,  
the sooner your life will get better!**

A bit over the top? Yes we know!  
We are just that sure that we can make your  
media activities more effective.



Get "Bookboon's Free Media Advice"  
Email [kbm@bookboon.com](mailto:kbm@bookboon.com)



The Project Management Plan is a living document, and evolves as the project evolves.

According to the PMBOK®, the following is a list of the key deliverables in a Project Management Plan. They can either be separate chapters of the document, or separate documents (if the project is very large).

- Project Management approach
- Work Breakdown Structure (to the level at which control will be exercised)
- Budget
- Scheduled start and finish dates
- Responsibility Charts/Assignments
- Change Control plan/system
- Performance Measurement Baselines
- Major Milestones and their target dates
- Resources
- Risk Management Plan
- Open Issues
- Pending Decisions
- Project Organisation Chart

It is important to have been through this list and decided what is applicable to YOUR project.

At the start of the project, we may only have a high-level understanding of the various deliverables (for example: we may only have an overall budget or end-date), and not yet be able to give more detail. As we advance in the project, we will be able to fill in more and more detail.

### 3.1 Project Planning Checklist

Project Step	Step Description	Inputs	Outputs	Comments
Scope Planning	Developing a Scope Statement – detailing what the project will achieve	Project Charter	Scope Statement	Why, What, When, Who, How Much, Where, How Many?
Team Development	Creating the Team			
Scope Definition	Subdividing the Scope into deliverables	Scope Statement	Work Breakdown Structure	
Activity Definition	Subdividing the Work Packages into Activities	Work Breakdown Structure	Activity List	MS Project?
Activity Sequencing	Identifying interdependencies between activities	Activity List	Project Network Diagram	Either by activities or by Work Packages



Project Step	Step Description	Inputs	Outputs	Comments
Activity Duration Estimating	Estimating the time each activity/Work Package takes	Project Network Diagram		Take into account the resources available, the effort and durations required
Schedule Development	Developing the Project Schedule	Project Network Diagram	Schedule (Gantt)	
Staff Acquisition	Getting the right people	Schedule (Gantt)	Project Staff assigned	Get the best people for the jobs; negotiate with line managers
Cost Estimating	Estimating the cost of the project	Schedule (Gantt)	Cost Budget	Take into account the duration, the efforts required, and other costs
Risk Management Planning	Defining the procedure for managing risks		Risk Management Plan	What is the risk threshold; how to manage; when to hold meetings, etc.
Project Plan Development	Defining the integrated Project Plan	all subsidiary plans	Project Plan	First do all individual plans, then integrate into Integrated Project Plan
Quality Planning	Defining the procedure for managing quality		Quality Management Plan	
Communications Planning	Defining the procedure for managing communications		Communications Management Plan	What; to Whom; When; How; Where; by Whom
Risk Identification	Brainstorming to list all possible risks	WBS; Experience; Risk categories	Risk List	Use negative brainstorming
Risk Analysis	Ranking risks by importance (Impact x Probability)	Risk List	Ranked Risk List	(excel spreadsheet)
Risk Response Planning	Creating actions to take to lower impact or probability	Ranked Risk List	Risk Action Plan	(same excel spreadsheet – remember person responsible and end date)
Procurement Planning	Define what to buy and how	WBS	Procurement Management Plan	Roles of PM in procurement; role of Purchasing department
Procurement	Buying goods or services needed for the project	Procurement Management Plan		

Figure 8: Project Planning Checklist

**Success Factor:** If you don't know where you are going and how to get there, you will most likely not get where you want – or get there in time.

### 3.2 Kick-Off Meeting

In order to get the Project Team working together quickly and efficiently, we strongly recommend that you hold a kick-off meeting as early as possible in the project. This meeting can last ½ day or 1 day, and should address the following points:

1. Introductions
2. Presentation of Project
3. Scope Statement
4. Team Work Questionnaire
5. Conflict Management Questionnaire
6. Work Breakdown Structure for Project
7. Resource Assignment Matrix for Project
8. Network Diagram of Project
9. Agreement on Culture, Behaviours, Standards
10. Meeting Standards and Norms

### 3.3 Work Breakdown Structure

A Work Breakdown Structure (WBS) is another of the key factors for project success.

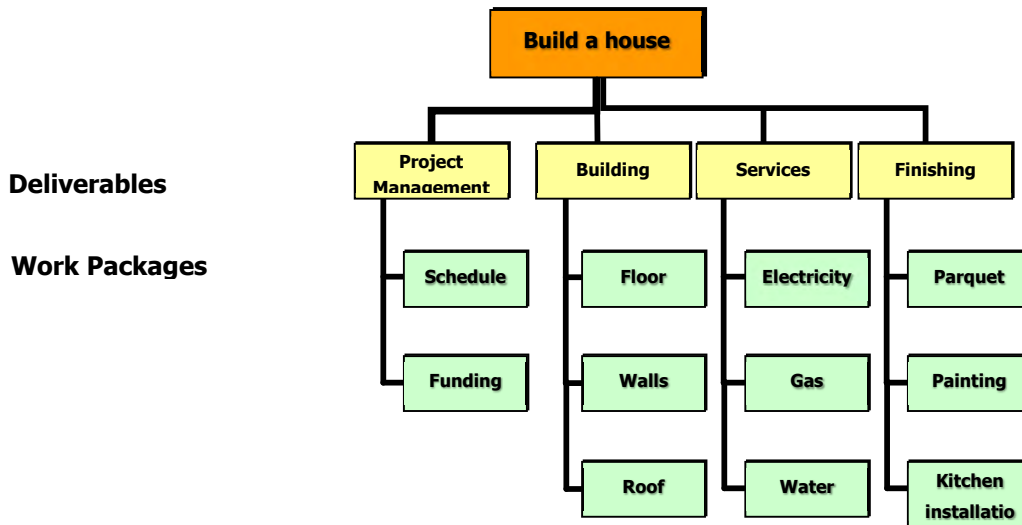



Figure 9: WBS Example

It is a diagram that breaks down the work to be done (a “WHAT” Breakdown Structure) in the project.

 Take a short-cut to your next job!  
Improve your interview success rate by 70%.

 **TheCVagency**  
Visit [theagency.co.uk](http://theagency.co.uk) for more info.

Download free eBooks at [bookboon.com](http://bookboon.com)

  Click on the ad to read more

At the top, you enter the name of the project. Then on the second level (yellow in our diagram), you enter the top deliverables of the project. Make sure always to have “Project Management” as your first Deliverable. The reason for this is that there are a lot of activities and work packages related to managing the project, and not just those related to the result of the project itself.

For the third and subsequent levels, the question to ask is: “what do I need to do to achieve the level / box above?”

The most important thing to remember is that at the end of this exercise, you have all the work packages and only the work packages necessary to produce the project result.

You may find that a single work package in a WBS for one Project Manager becomes a whole project for another Project Manager.

### WBS – Rules of Thumb

A “Rule of Thumb” is not a rule or a law. It is a strategy that we do because we know it works.

- There is no rule as to the number of levels that a WBS has
- Always start with Project Management as the first Deliverable
- There should be no more than 10 top-level Deliverables
- Use a Noun: Object naming convention
- Each sub-component must have a deliverable... the lowest level of sub-division with a deliverable is called a “work package”
- Each and every sub-component must be assignable to one and only one person...
- Do not break the work into any finer detail than you intend to track or is of value – do not micro-manage

**Success Factor:** Creating the WBS with your team will ensure common understanding of the big picture and how each person fits in.

## 3.4 Network Diagram

Once you have your list of low-level Work Packages, they should be sequenced into a Network Diagram and given time estimates

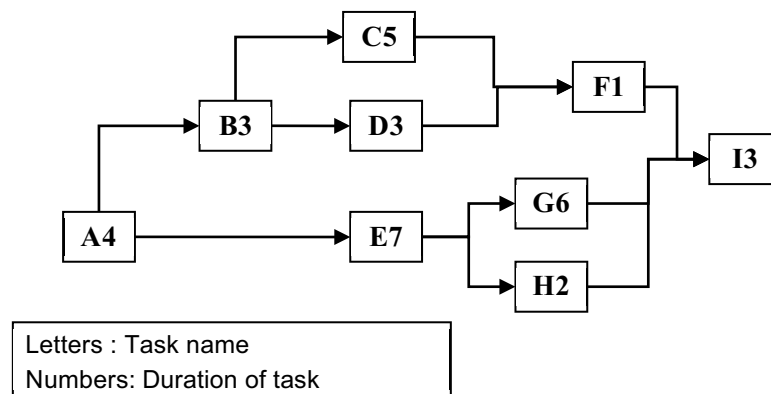

**Figure 10:** Network Diagram Example

Building the Network Diagram with your team is another of the key factors for project success.

Remember to take only the **LOWEST** level post-its (Work Packages) and then re-organise them in a timeline, from **START** to **FINISH**.

We are looking for **DEPENDENCIES**:

- What work needs to be done before I can start another work package?
- What work can be done in parallel (at the same time)?

We will also write the names of the responsible people on each of our Work Packages.

### 3.4.1 Duration vs. Effort

Remember that Duration is not the same as Effort. In the Network Diagram, please enter **DURATION**. This is the time a task should take to be completed, in an ideal situation.

Creating the Network Diagram is an iterative process. Once you see the length of time the project lasts in an ideal world, you then start to take reality into consideration:

- Number of people
- Weekends
- Holidays
- Multi-tasking
- Etc.

We can use several tools to visualise our project information. Some Project Managers use MS Project or other scheduling tools (Primavera, etc.). Others use a simple EXCEL sheet.

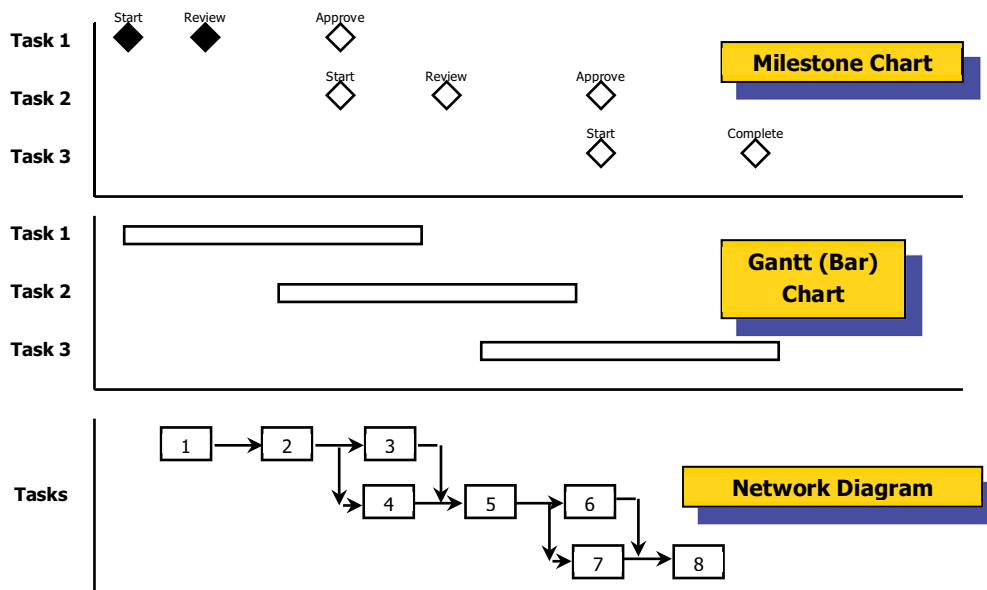

Figure 11: Project Visualisation Tools

It is important to clearly define the project tasks, and to show them in a timeline in relation to one another, in order to see if the project is realistic.

## Bøger til forandring og vækst

Forlaget Birmar har i over 10 år udgivet bøger, som er kendetegnet ved at være direkte anvendelige i udviklingen af virksomhed og organisation, ledelse og personlig udvikling. Blandt nyhederne er:



Se alle vores bøger på [www.birmar.dk](http://www.birmar.dk)

Her kan de også købes i det fulde omfang.

Se alle vores bøger på [www.birmar.dk](http://www.birmar.dk) – her kan de også købes i det fulde omfang.

**Nyhed fra forlaget:**

**BOG + FOREDRAG = MERVÆRDI**

Forlaget Birmar A/S  
Strandmøllevej 2  
6000 Kolding  
Tlf.: 75 50 15 29  
Fax: 75 53 36 60



A Gantt Chart is extremely useful as a communication tool, and if you put a vertical line on today’s date, you can see what has already been achieved and what still has to be achieved.

We prefer to show the Milestones within the Gantt Chart.

### 3.4.2 Network Diagram Analysis

Once we have created the Network Diagram, we will start to use it to define two more critical success factors:

**Critical Path** – the path through the network where the tasks have NO FLOAT. If any one of these tasks is even one day late, it will delay the whole project. These are the CRITICAL TASKS.

**Float** – those tasks that are NOT on the Critical Path will have more flexibility in when you can start them. There is room to manoeuvre.

#### Forward Pass

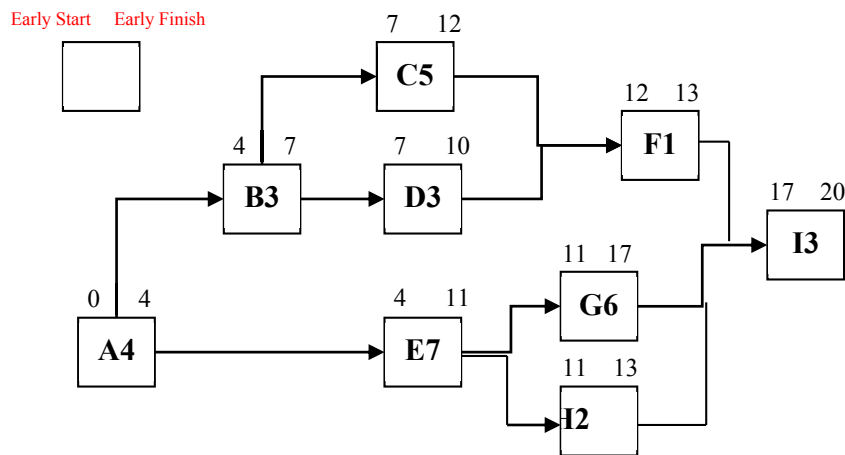

Figure 12: Forward Pass Example

Remember to start on day “0”.

You then add the time the task takes, which gives you the Early Finish day of that task. You move the number across to the following task, and repeat.

When you have two tasks going into one task, you take the HIGHER of the two numbers.

Once you have completed your Forward Pass, you will see how long the project will take in the best of all worlds.

We have not taken into consideration the resources we have, weekends, holidays, etc.

We are now ready to calculate our Backward Pass.

**Backward Pass**

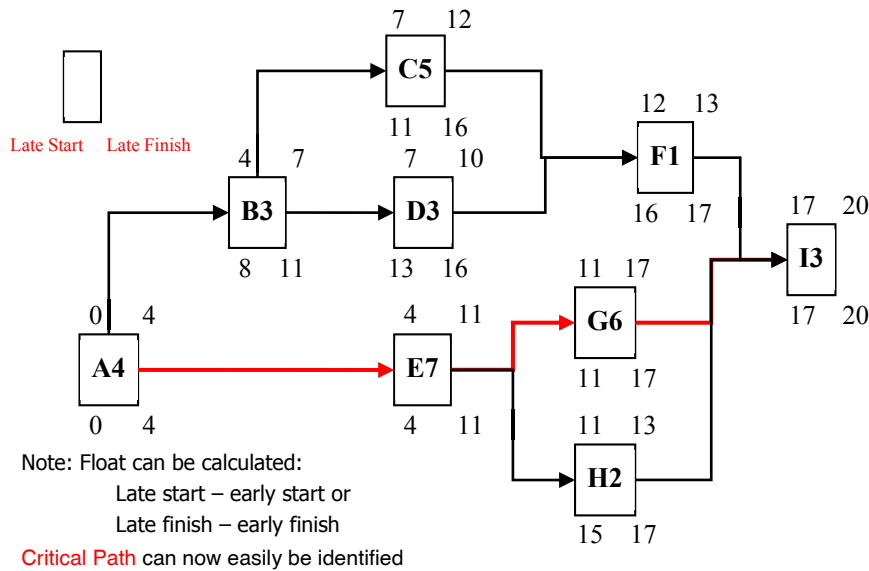

**Figure 12:** Backward Pass Example

The backward Pass starts from the back, and SUBTRACTS the task duration.

When you have two tasks going into one (for example, C and D go into B), then choose the LOWER number.

When you have completed your Backward Pass, you will be able to find your Critical Tasks, and by stringing them together, you will see your Critical Path (or Paths).

A way to check that you did the Backward Pass correctly is to ensure that the first task(s) have Early Start and Late Start both as “0”.

The tasks that are not on the Critical Path will have some amount of FLOAT.

Float is calculated by subtracting the top left number from the bottom left number for the task (for example, in C5, 11-7 = 4. Task C has 4 days of float).



**Success Factor:** Build and analyze the Network Diagram with your team for common understanding and a common base for planning.

### 3.5 Gantt Chart

Once you have found the Critical Path and calculated the shortest length of time that the project can take, then you can start to place the tasks on a Gantt Chart. This will start to add more reality to the project timing. You will be able to add weekends and holidays to the timeline.

Of course, this means that the total time the project will take will be longer than the Critical Path duration (26 days instead of 20 days).



**VI KUNNE IKKE DRØMME  
OM AT SINKE DIG  
OG DIN KARRIERE...**

*www.mh.dk*

**Merkonomernes  
Hovedorganisation**

*Vi er til for dig – og du bestemmer tempoet!*

Merkonomernes Hovedorganisation er en landsdækkende faglig organisation – med egen A-kasse for Merkonomer, AkademiMerkonomer, Agrarøkonomer, studerende og andre med tilsvarende uddannelser.



Work Package	Responsible	Duration																												
			1	2	3	4	5	6	7	8	9	0	1	2	3	4	5	6	7	8	9	0	1	2	2	2	2	2	2	2
A		4																												
B		3																												
C		5																												
D		3																												
E		7																												
F		1																												
G		6																												
H		2																												
I		3																												

Figure 13: Gantt Chart Example

### 3.6 Managing Risks

Once we have defined the WBS, the Network Diagram, and the Critical Path, we are in a position to be able to define our risks in more detail.

Risk Management is one of the most CRITICAL Success Factors.

If you manage your risks actively, you can save money for the company, and you have a much greater chance of finishing your project on time, on budget, and with happy customers and other stakeholders.

The process is a simple step-by-step check-list:

1. Identify risks
2. Evaluate probability
3. Evaluate impact
4. Document
5. For medium and high risks, define Action Plan (with dates)
6. For high risks, define Contingency Plan
7. Manage actions
8. Evaluate results
9. Repeat at weekly project meetings

Please ensure that you repeat the process every week, since risks change, and if you ignore them, they very often very quickly turn into problems.



Only when you have analysed the risks can you start to decide what to do to avoid them becoming reality (or ISSUES).

We recommend placing the risks in a Risk Register – an excel sheet (with a description of their consequences, their Probability and Impact numbers, and the multiplication of the two – the X-factor – which allows you to sort the risks by their importance).

You can then code the risks by colour: RED, YELLOW and GREEN.

- Those of high risk (RED) should be resolved, transferred or mitigated
- Those of medium risk (YELLOW) should be resolved or a contingency plan developed
- Those of low risk (GREEN) should be left to the team members to solve

Your goal should then be to carry out the actions necessary to have only yellow and green risks.

It may not be possible to do all the actions for every risk. It is therefore important to analyse each risk and decide WHAT TO DO.

## Hvor mange skal tage en beslutning, før man kan føre en beslutning ud i livet?



Slip for komplekse kommandoveje. Hos NNIT løser vi de store it-opgaver i små teams, der ikke skal spørge om lov til at tage en beslutning. Se ledige job på [nnit.dk/job](http://nnit.dk/job)

**nnit**

Conscience driven. Value adding



<b>Avoid</b>	<b>Eliminate threat by eliminating the cause</b>
<b>Transfer</b>	<b>Shift responsibility to third party (i.e. Insurance or supplier)</b>
<b>Mitigate</b>	<b>Reduce probability and/or impact – create Mitigation Plan and Reserve Plan</b>
<b>Accept</b>	<b>Accept and create contingency reserves</b>

**Figure 15:** Risk Strategies

It is also important to add the action, the due date, and the person responsible to your Risk Register.

**Success Factor:** Actively managing your risks will allow you to proactively manage your project and see problems coming in time to save the project.

### 3.7 Teams

Think back to the teams you have been part of – this could be a team at work, sport, or other hobbies.

Think of the BEST team you ever worked in, then think of the WORST team. What was the difference? What made one team so great and the other team not?

As a Project Manager, you have the choice as to which type of a team you create. It is YOUR job to help the team become really great. If you think of the best team you have been on, many of the above characteristics were most likely there.

A successful team:

- **Meets Stakeholders expectations** – it knows what the expectations are, and is able to meet them.
- **Reduces barriers** – between the team members, and between the team and the Team Leader. The team members know and respect one another's differences and similarities.
- **Embraces and controls change** – if there is one thing we can be certain about in Projects, it is that we will have change. A successful team uses this to move forward, to learn and grow, and to continuously improve the way they work.

- **Ground rules** – without ground rules, nobody knows what is acceptable and what is not. Ground rules can be written, or just talked about, but a successful team has clear ground rules (or expectations) right from the start.
- **Communicates** – a successful team communicates openly. The notion that “information is power” does not apply.
- **Mutual Accountability** – As a team, we feel responsible and accountable for one another and our common results. We work together to produce a team result.
- **Collaborative creativity** – this allows us to find new and innovative solutions to problems or questions. We are able to work together effectively and as a team, be more creative than as individuals.
- **Joint decisions** – a successful team is used to taking decisions together. The Team Leader is there to help, and at times to take final decisions, but the team actively participates.
- **Appropriate initiative** – a Team Leader should make sure that the team members feel valued and empowered enough to take the initiative when needed – that they do not feel they have to wait for their Lead. This saves time, and motivates people to do even better.

Any team you can think of – in work, sports, or other activities – even a relationship – goes through a series of steps before they can become truly effective and “performing”.

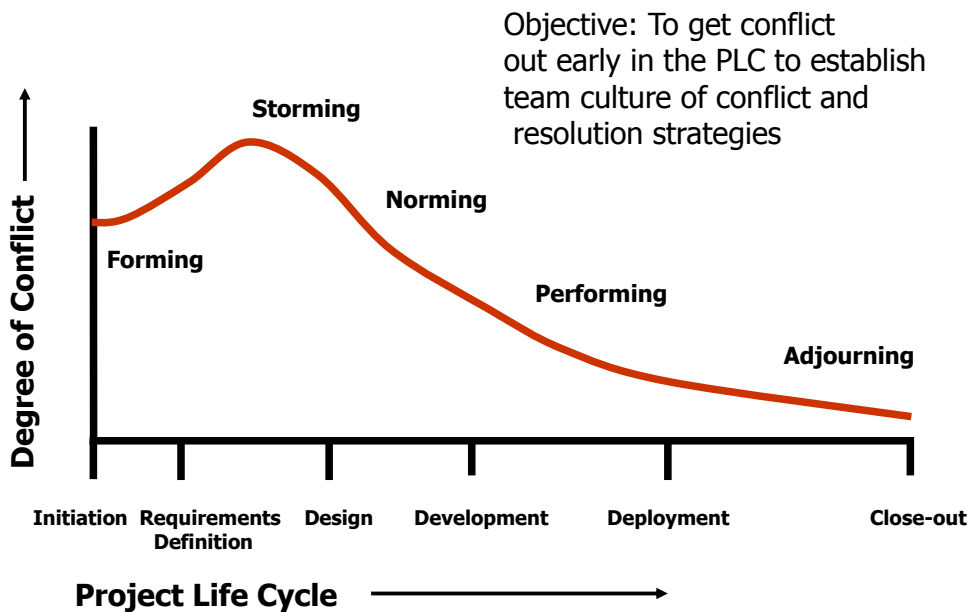

Figure 16: Team Life Cycle

The first stage – **Forming** – is when we first meet. We don’t know each other yet, we are polite, we hold back, and are waiting to understand what the others are like, what their positions are, their thoughts and opinions, and where we all fit into the team:

**Storming** – It is necessary to go through the storming phase before a team can start to perform. Storming may not mean outright fights and conflict, but it is the phase where team members start to voice their opinions, and to make their place in the team. It is the phase where we realise that we do not all agree with one another all the time, and it is where we start to discover how to make decisions and come to agreement as a team.

**Norming** – once the team members have found their place, and found strategies for making decisions and coming to agreement, the team relaxes a bit, and starts to feel more comfortable.

**Performing** – in a project, time is very important, so the quicker the Project Manager can bring the team to performing, the better. Without the storming phase, a team will never get to performing, so it is important to create the storming (in a controlled way!) by having a kick-off meeting, by making sure the team has to make decisions that affect the individuals at an early stage.

**Adjourning** – every project ends, so every Project Team will come to an end. This phase has also to be managed by the Project Manager, to make sure the team members feel valued enough to want to work in the team again, and to make sure that they feel that the project “chapter” has closed. Having a celebration or just a team dinner or team drink at the end of the project is very important.



**Success Factor:** It is your role as Project Manager to get the team working efficiently together as FAST as possible. We have little time to waste in projects.

### 3.7.1 Roles in Teams

These are the natural roles that people will play in teams. Every role is necessary for a performing team. Meredith Belbin has developed the following list of roles that people in teams play:

**Organiser** – The Organiser’s role is to direct the group, but this tends not to be done in an overbearing manner. They are dominant without being overly assertive.

**President** – The President’s concern is to win to reach goals by putting every effort into the process. They are highly motivated. They have a high degree of nervous energy and a great need for achievement.

**Doer** – The Doer is conscientious and is concerned with detail. Doers are excellent doers of schemes which others have devised. Doers prefer to work alone.

**Creative** – They are creative and innovative. They are responsible for the production of ingenious new ideas and novel strategies. They are very bright; their ideas may often be radical and practical constraints may sometimes be overlooked.

**Enlightener** – The Enlightener, as the name suggests, is good at finding out what is available and what can be done. They ask questions to make sure everyone understands, and to clarify information.

**Evaluator** – The Evaluator is very good at weighing up the facts, carefully considering the pros and cons of each option, and finally coming to a well considered decision.

**Co-worker** – The Co-worker is a good communicator, trusting, sensitive and caring. They will tend to place the group’s objectives and the smooth running maintenance of the group itself before their own personal ambition.

**Finaliser** – The Finaliser pays attention to detail. They are hard working and conscientious. As their title suggests they are good at picking up the loose ends and tying them up.



**Success Factor:** Give your team members the Belbin Team Roles Questionnaire to ensure everybody understands more about their roles and how to work together.

### 3.7.2 Virtual Teams – the 6 Challenges

Six major challenges are driving virtual teams apart:

#### 1. Cross-culture differences:

Many studies have been done on the differences between cultures. There seems to be agreement on some basic areas of difference, and this has been summed up in The Cultural Orientation Framework (COF) which was developed by Philippe Rosinski based on the works of many known experts in the intercultural field, including Hofstede and Trompenaars. The full model is published in the book, *Coaching Across Cultures*.

##### a) Sense of Power and Responsibility

**Control:** People have a determinant power and responsibility to forge the life they want.

**Harmony:** Strive for balance and harmony with nature.

**Humility:** Accept inevitable natural limitations.

##### b) Time Management Approaches

**Scarce:** Time is a scarce resource. Manage it carefully!

**Plentiful:** Time is abundant. Relax!

**Monochronic:** Concentrate on one activity and/or relationship at a time.

**Polychronic:** Concentrate simultaneously on multiple tasks and/or relationships

**Past:** Learn from the past. The present is essentially a continuation or a repetition of past occurrences.

**Present:** Focus on the “here and now” and short-term benefits.

**Future:** Have a bias toward long-term benefits. Promote a far-reaching vision.

##### c) Definitions of Identity and Purpose

**Being:** Stress living itself and the development of talents and relationships.

**Doing:** Focus on accomplishments and visible achievements.

**Individualistic:** Emphasize individual attributes and projects.

**Collectivistic:** Emphasize affiliation with a group.

#### d) Organizational Arrangements

**Hierarchy:** Society and organizations must be socially stratified to function properly.

**Equality:** People are equals who often happen to play different roles.

**Universalist:** All cases should be treated in the same universal manner. Adopt common processes for consistency and economies of scale.

**Particularist:** Emphasize particular circumstances. Favour decentralization and tailored solutions.

**Stability:** Value a static and orderly environment. Encourage efficiency through systematic and disciplined work. Minimize change and ambiguity, perceived as disruptive.

**Change:** Value a dynamic and flexible environment. Promote effectiveness through adaptability and innovation. Avoid routine, perceived as boring.

**Competitive:** Promote success and progress through competitive stimulation.

**Collaborative:** Promote success and progress through mutual support, sharing of best practices, and solidarity.

#### e) Notions of Territory and Boundaries

**Protective:** Protect yourself by keeping personal life and feelings private (mental boundaries) and by minimizing intrusions in your physical space (physical boundaries).

**Sharing:** Build closer relationships by sharing your psychological and physical domains.



## SÆT LYD PÅ FREMTIDEN

Widex udvikler højteknologiske høreapparater til gavn for de 500 millioner mennesker verden over, der har nedsat hørelse.

Mere end fem årtiers intensiv forskning og udvikling har gjort os til en af verdens førende høreapparatproducenter, og vi udvikler digital teknologi af en kvalitet, kun få kan måle sig med.

Som videnbaseret virksomhed betragter vi medarbejderne som vores vigtigste kapital. Vi kan godt lide at gøre tingene selv og sætter en ære i at være selvforsynende inden for de fleste områder. Det skaber et spændende, tværfagligt arbejdsmiljø med plads til initiativ og rig mulighed for personlig og faglig udvikling.

Vil du være med til at sætte lyd på fremtiden?  
Følg med i vores jobopslag på [www.widex.dk/job](http://www.widex.dk/job)  
eller skriv til [jobbox@widex.com](mailto:jobbox@widex.com)



[www.widex.com](http://www.widex.com)



f) **Communication Patterns**

**High Context:** Rely on implicit communication. Appreciate the meaning of gestures, posture, and voice and context.

**Low Context:** Rely on explicit communication. Favour clear and detailed instructions.

**Direct:** In a conflict or with a tough message to deliver, get your point across clearly at the risk of offending or hurting.

**Indirect:** In a conflict or with a tough message to deliver, favor maintaining a cordial relationship at the risk of misunderstanding.

**Affective:** Display emotions and warmth when communicating. Establishing and maintaining personal and social connections is key.

**Neutral:** Stress conciseness, precision, and detachment when communicating.

**Formal:** Observe strict protocols and rituals.

**Informal:** Favour familiarity and spontaneity.

g) **Modes of Thinking**

**Deductive:** Emphasize concepts, theories, and general principles. Then, through logical reasoning, derive practical applications and solutions.

**Inductive:** Start with experiences, concrete situations, and cases. Then using intuition, formulate general models and theories.

**Analytical:** Separate a whole into its constituent elements. Dissect a problem into smaller chunks.

**Systemic:** Assemble the parts into a cohesive whole. Explore connections between elements and focus on the whole system.

2. **Time differences:** It is harder to coordinate working in different time zones, with different holiday calendars.
3. **Communication:** The majority of our communication is non-verbal and gets lost when we communicate over e-mail or by phone. Misunderstandings and miscommunication is more likely.
4. **Coordination:** Project work requires countless small adjustments, such as a question about where to get certain information, a request for clarification, etc. In collocated teams, these adjustments can be done quickly and informally (i.e. at the water cooler).
5. **Cohesion barriers:** Groups that are collocated develop closer bonds and are more likely to trust each other, help each other, and work harder for each other. Since this bonding happens in informal settings and needs non-verbal communication, it is much harder to develop in virtual teams.
6. **Control:** “Out of sight – out of mind” is a major challenge for all virtual managers. Control efforts without seeing, observing, and face-to-face dialogues with the staff are less effective. The result is more duplication of efforts, late discovery of problems, and more rework.

### 3.7.3 Six Rules for Leading Virtual Teams

#### 1. Create a trustful environment

Whenever you lead a virtual team, you have little or no authority or control over the team members.

You have to trust that your team members are doing the job perfectly.

A best practice approach is to create trustworthy relationships. Therefore, every single step in the project has to deepen the trust in:

You as the leader of the virtual team

Your virtual project or virtual company

All virtual team members

Trust all your team members, especially in the beginning. If you demonstrate trust, then your team members are likely to develop trust as well.

#### 2. Establish meaningful team specific symbols

Because virtual teams are not located at one place of work, you have to establish meaningful symbols so that your team members feel connected closely, even over a distance:

If possible, have a face-to-face kickoff meeting or at least a video-conference.

Make sure that all team members know their personal benefits from being part of this team.

Be creative in finding recognitions and rewards to show appreciation for the performance of individuals and the team.

#### 3. Facilitate opportunities for team members to get to know each other

Because virtual team members have only limited personal contact, you have to make sure that the team members can learn more about each other:

Provide space for team members to learn more about each other with a full profile of all team members covering professional and private aspects, including their birthdays and hobbies.

Have a monthly project newsletter with a wide range of contributions. If possible arrange at least an annual meeting of the project team.

Have a short personal, informal meeting with the team on a regular basis discussing problems and getting feedback on each other.

Encourage your team members to organize themselves in smaller workgroups of two to three people to work on some areas of the project. The RAM is a great tool to formalize this approach.

Encourage your team members to bring ideas forward. Appreciate all ideas of your team members. Make sure that your reaction to the ideas is perceived as fair.

#### 4. Create a clear vision

With virtual teams, there are frequently breakdowns and loss of motivation after face-to-face meetings. Therefore you should:

- Create clear and understandable intellectual bonds so that all team members know what the objectives of the team are
- Create a strong emotional relationship on the personal level that works across long distances
- Have a clear vision that supports all team members with daily guidance

A good tool to support you here is the Project Charter that we saw previously.

## Do you know Schneider Electric?

We are a global specialist in energy management represented in more than 100 countries. We provide technology and integrated solutions to optimise energy usage across multiple market segments. We are more than 130,000 colleagues worldwide and 1.000 of us are situated in Denmark.

We invest in our employees, in the environment and in the future. Each year 5% of our revenue is allocated for research and development activities. In Schneider Electric you have many career paths to choose from – also internationally.

Would you like take on the challenge of transforming  
the way people and organisations use energy?



Meet us at:  
[www.schneider-electric.dk/job](http://www.schneider-electric.dk/job)

**Schneider**  
Electric



### 5. **Treat everyone equally, regardless of distance**

It is important that all team members feel fairly treated, regardless of whether they are close or distant. If one team member is perceived as getting special treatment, then this can damage the level of trust and confidence quickly:

- Avoid the temptation to have more contacts with team members who are physically located closer to you
- Treat all needs of all team members alike
- Give everybody the opportunity of being seen and contributing meaningfully to the achievements of the team
- React immediately if you spot poor performance. You have to correct unacceptable performances and behaviours despite the long distances to bridge.
- Act predictably and fairly; make sure all members are fully responsible for their acts and performances

### 6. **Use multi-channel communications.**

Bad communication and uneven distribution of information can quickly destroy the trust within a virtual team. Problems are sometimes hidden for several months until they become visible.

During this time, they slow down progress and reduce the productivity of the virtual team and project. Therefore make sure that you communicate clearly by including:

- Visual clues – pictures, graphics, diagrams, tables
- Tangible clues – things to touch, to sense, to experience
- Verbal clues – details, analysis, comparisons, examples, processes

It is your responsibility to ensure that the communication flows are effective within the project and team. A good tool to support you here is the communication plan.

**Success Factor:** Be sure to establish ground rules with your team and communicate often – especially when working in a virtual environment.

3.7.4 Responsibility Assignment Matrix

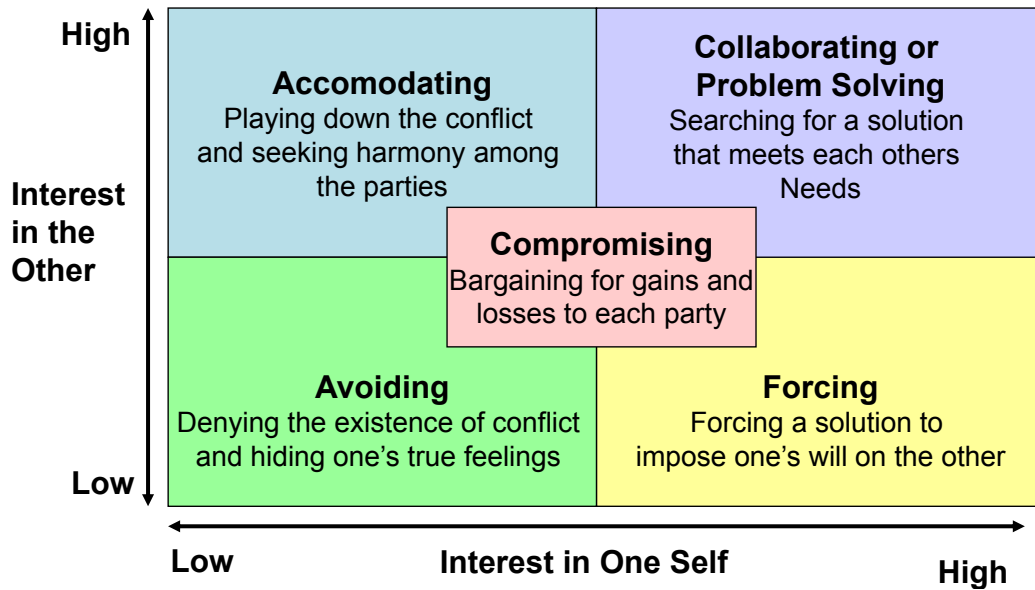

Figure 17: Responsibility Assignment Matrix Example

Another key success factor for your project is to make sure that right from the start of the project, every team member knows who is doing what.

The easiest way to make sure this happens is to use this matrix – the Responsibility Assignment Matrix.

It is important to list the Work Packages for the project down the left hand side of the matrix, and then list all the members of the project team as well as all other stakeholders who will be playing an active role in the project across the top.

**Responsible** – The person who will have responsibility and accountability for making sure the work package is achieved

**Approves** – the person who signs off the work package

**Supports** – the person who will help the Responsible achieve the work package

**Informed** – the person who needs to be kept informed about the work package – the person you copy on an email or invite to a meeting

**Consulted** – the expert or other person who you need input from, for the work package

Watch out for: more than one “R” for a Work Package.

**Success Factor:** Make sure that right from the start of the project, every team member knows who is responsible for what.

# IFRS 2012

## – nu også som e-bog

IFRS 2012, Standarder og fortolkningsbidrag – på dansk fås nu både som trykt bog samt som e-bog til smartphone, tablet og pc.

Introduktionspris: e-bog og trykt bog kr. 1545,-

 E-bog inkl. opdateringer i 2012

Læs mere og køb e-bogen sammen med den trykte bog her:  
[shop.magnus.dk](http://shop.magnus.dk)



REGNSKAB

 Magnus Informatik  
a Wolters Kluwer business





# 4 Execution

Once we have initiated and planned for the project, it is finally time to start executing the work packages. This is where all the skills of a Project Manager become important. He has to be able to coordinate the work, and also motivate and coordinate the people involved. The Project Manager should show a balance of technical and people skills, and of Management and Leadership skills.

If all the processes and procedures have been defined and communicated during the Initiation and Planning phases, then it will become much easier for the Project Manager to just apply them.

Examples of processes are:

- Escalation
- Risk Management
- Change Management
- Conflict

## 4.1 Conflicts

We all naturally act or react in certain ways when faced with conflict. There is no bad or wrong way. There are just ways that work better than others in certain situations. Thomas Kilmann has developed the following matrix that explains the different strategies people use to manage conflict:

<b>Project ABC</b> <b>PHASE</b>	<b>PERSON</b>	<b>A</b>	<b>B</b>	<b>C</b>	<b>D</b>	<b>E</b>
		<b>Requirements</b>	<b>R</b>	<b>S</b>	<b>I</b>	<b>C</b>
<b>Define</b>	<b>I</b>	<b>A</b>	<b>R</b>	<b>S</b>	<b>C</b>	
<b>Design</b>	<b>I</b>	<b>A</b>	<b>R</b>	<b>C</b>	<b>S</b>	
<b>Develop</b>	<b>A</b>	<b>I</b>	<b>S</b>	<b>R</b>	<b>R</b>	
<b>Test</b>	<b>S</b>	<b>R</b>	<b>A</b>	<b>I</b>	<b>C</b>	

**R – Responsible A – Approves S – Supports I – Informed C – Consulted**

**Figure 18:** Conflict Management Strategies

There are times when it is necessary to “force”, and times when we may choose our battles.

When possible, do try the “**collaboration**” strategy. It may give surprising results, and in any case, the conflict will disappear into thin air, replaced by a common problem to solve.

Instead of using the words “you” and “me”, we start to use the words “us” and “we”.

We stop taking positions, and start to be able to see the bigger picture, and become more creative about the solutions.

**Success Factor:** Explain the different strategies to your team, take the Kilmann Conflict Mode Instrument questionnaire, and agree to try to use Collaboration whenever possible.

## 4.2 Managing Changes in Projects

Changes to a project are inevitable. It is the one thing we can be sure of in a project: there WILL be change. It is how we manage the changes and the requests for changes that will make the difference between a successful project and a failure.

One of the key factors for project success is well-managed changes.

When managing your project, it is important to have a process in place for managing the changes to the project. They will happen, so you may as well manage them well, and thus have more chance for succeeding your project.

1. Make sure that all the stakeholders know what the Change Process is. It does not need to be very heavy, maybe just an email requesting the change can be enough.
2. Make sure the change is real – that it is relevant to the project.
3. Then define the consequences that the change will have on the project. Think of your Triple Constrains: Time, Cost, Scope, Quality, Resources.
4. The decision on whether to accept or reject the change is often not for the Project Manager to make. Make sure that the person who owns the project (the customer, the sponsor) is the one who takes the decision – with your help and advice, of course.
5. If the decision is to accept the change, then it is your job as Project Manager to incorporate the change into the project and to manage the change.

**Remember: keep the decisions where they belong!**

**Example of a Change Request Form**

<b>Project Name</b>			
<b>Project Number</b>	<b>Change ref.</b>	<b>Date</b>	<b>Raised by</b>
<b>Change Description Summary</b> <i>(also attach a full change description and impact assessment)</i>			
Reason for change			
(Tick Box) <b>New</b>	<b>Revised</b>		<b>Other (Specify):</b>
<b>Impact assessment</b> <i>(compared to current project definition)</i>			
<b>Scope</b>			
<b>Cost</b>			
<b>Delivery</b>			
<b>Resources</b>			
<b>Benefits</b>			
<b>Risks</b>			
<b>Priority of request</b> <i>(high, medium, low)</i>			

	<b>Signed</b>	<b>Name in Block capitals</b>	<b>Date</b>
<b>Project Manager</b>	.....	.....	.....
<b>Change Co-ordinator</b>	.....	.....	.....
<b>Project Sponsor</b>	.....	.....	.....

**Figure 19:** Change Request Form Example

**Success Factor:** Changes are inevitable. It is HOW YOU MANAGE THEM that will make the difference between a successful and failed project.

### 4.3 Resistance to Change

We use the same words to describe the management of changes to the project, and the management of changes in the organisation due to the outcome of the project: Change Management.

We will use the words “Resistance to Change” when talking about the way people will react when faced with changes in the way they work, due to the project results.

In any case, we will need to manage these reactions, to make sure that when the project finishes, and the results are in place, the stakeholders accept the new.

Every time a person is faced with a change that they perceive to be negative, they will go through a series of emotional responses.

This is seen in work life, and also in private life. The change can be moving to another town or country, divorce, losing a job, or just having to use a new computer system or way of working.

# Dine **fordele** ved forsikring hos **Pantaenius**



**Hjælp ved uheld**  
Du har behov for bugsering til nærmeste værft?  
Pantaenius overtager omkostningerne dog begrænset op til DKK 37.500,00!



**Inspektionsomkostninger**  
Du har haft en grundstødning og vil have bunden inspiceret?  
Pantaenius dækker inspektionen uden selvrisiko!



**Kontakt os**  
Har du spørgsmål til dine forsikringer?  
Du kan ringe +45-9751 33 88 eller skrive til os på e-mail [info@pantaenius.dk](mailto:info@pantaenius.dk)



**Ingen selvrisiko**  
Indbrud, transportskade, brand, lynnedslag eller totalskade?  
Ved disse skadesårsager er der ingen selvrisiko hos Pantaenius!

Østerbro 11 · 7800 Skive  
Tel. +45-9751 3388 · [info@pantaenius.dk](mailto:info@pantaenius.dk)  
[www.pantaenius.dk](http://www.pantaenius.dk)



**PANTAENIUS**  
Agentur for Lystfartøjsforsikring

DEN1003 www.hjphude 01/2012



Below is a diagram developed by Daryl Conner, expanding on Elizabeth Kübler-Ross's five-stage model. A psychiatrist by training, Kübler-Ross interviewed several hundred terminally ill patients and their families, eventually developing a means for understanding the process that people undergo as they come to terms with impending death. (This was first described in her 1969 book *On Death and Dying*.) According to her model, people evolve through a series of stages as they confront their own mortality or that of a loved one.

A person will go through the cycle at different speeds, depending on their situation, and it is the job of the Project Manager to help them through the various stages, to get to the "Acceptance" of the change.

For example, if you see that the person is at the "Depression" stage, then you may be able to help them move to the "Exploration" stage.

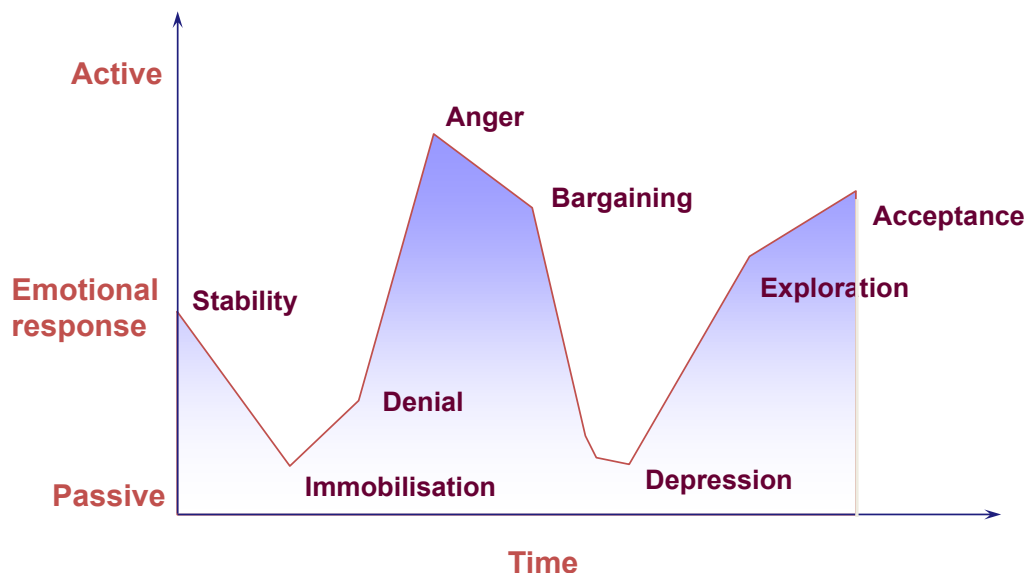

**Figure 20:** Emotional Responses to Change Over Time

As we know, change is inevitable. The problem is that people normally do not like change, and will react negatively towards change.

There are different reasons for this, as seen above, and if you, as Project Manager, are aware of these reasons, you may be able to avoid them.

- Lack of vision
- No management of the consequences
- Lack of experience in implementing change
- Lack of understanding or "buy in"
- Lack of support from management
- Change is imposed without consultation

### 4.3.1 The Burning Platform



**Figure 21:** The Burning Platform

A burning platform type decision exists when the organisation is facing a major (disruptive) change in which the cost (pain) for the status quo is prohibitively high.

The “burning platform” must be present to provide the impetus for change. Without it, organizations are more comfortable with the status quo.

You will also see this work for individuals. We will keep doing what we are used to doing until it becomes more painful to stay where we are than it does to move to the new situation.

### 4.3.2 John P. Kotter’s 8-Step Process

A great little book that we recommend is John P. Kotter’s “Our Iceberg is Melting”.

It is a story that shows how people react to change, and what the various roles that people can play in making change happen successfully.

You may want to read it, and get your team members to read it too, so that you can discuss how it can apply to your project and company.

#### **Set the stage**

1. Create a sense of Urgency – help others see the need for change and the importance of acting immediately.
2. Pull Together the Guiding Team – make sure there’s a powerful group guiding the change – one with leadership skills, credibility, communications ability, authority, analytical skills, and a sense of urgency.

#### **Decide what to do**

3. Develop the Change Vision and Strategy – clarify how the future will be different from the past, and how you can make the future a reality.

**Make it happen**

4. Communicate for Understanding and Buy-In – make sure as many others as possible understand and accept the vision and the strategy.
5. Empower others to Act – remove as many barriers as possible so that those who want to make the vision a reality can do so.
6. Produce Short-Term Wins – create some visible, unambiguous successes as soon as possible
7. Don't let Up – press harder and faster after the first successes. Be relentless with initiating change after change until the vision is a reality.

**Make it stick**

8. Create a New Culture – hold on to the new ways of behaving, and make sure they succeed, until they become strong enough to replace old traditions.

It is not enough to know that change will happen, and to know that people may react negatively. It is however important to project success that the stakeholders are managed actively, and that you have an action plan in place that you put into place. You may be surprised by the results you will find when you do this with your team. There are far more stakeholders who can resist than you may have thought.



**Træt af 100-vis af ansøgninger?**

Lad Assistance Personaleservice a/s hjælpe dig næste gang du skal ansætte en ny medarbejder. Et rekrutteringssamarbejde med Assistance sikrer virksomheden:

- En ressourcebesparelse på 50-70 timer
- Et kompetent og etisk ansættelsesforløb
- En professionel sparring
- Garantiperiode – op til 6 måneder

Kontakt os for et uforpligtende møde på telefon 33 55 00 90



**Success Factor:** Change in life is inevitable. It is how you help people accept and work with change that will make the difference between a successful and failed project.

### 4.3.3 Influencing Skills

One of the most important skills a Project Manager can learn is how to influence.

A Project Manager normally has all the responsibility for ensuring a successful project result, but he rarely has the power.

In order to be able to do his work, he will need to influence the stakeholders.

## 4.4 How to Influence Others?

There is no right way, nor is there only one way to influence others. Your job requires you to influence people just about all of the time. It may take the form of gaining support, inspiring others, persuading other people to become your champions, engaging someone's imagination, creating relationships. Whatever form it takes, being an excellent influencer makes your job easier.

Other people like being around influencers. There's an exciting buzz, or sense that things happen when they're about. It's because they don't sit around wishing things were different while moaning there's nothing they can do about it. They don't sit around blaming others or complaining about what needs fixing that will make things better. They see what needs doing and set about getting it done.

Truly excellent influencing skills require a healthy combination of interpersonal, communication, presentation and assertiveness techniques.

### **Coercion and manipulation**

Forcing people to do what you want, often against their will

Pushing, bullying, bludgeoning or haranguing DO NOT WORK! Like elephants, people will remember the experience.

If you force someone to do something you want, without taking their point of view into consideration, then the impression that person is left with is how they will see you forever.



### What works

People are far more willing to come halfway (or more) if they feel acknowledged, understood and appreciated. They may even end up doing or agreeing to something they wouldn't previously have done because they feel good about making the choice.

Influencing is about understanding yourself and the effect or impact you have on others. Though it can, on occasion, be one way, the primary relationship is two way, and it is about changing how others perceive you.

Influencing is about being able to move things forward, without pushing, forcing or telling others what to do.

Influencing others is about having the confidence and willingness to use yourself to make things happen.

#### 4.1.1 The 6 Principles of Persuasion

(By Robert B. Cialdini, Roselle L. Wissler, and Nicholas J. Schweitzer)

1. **The principle of liking.** People are more easily influenced by those they like. Although research has uncovered several factors that affect how much one person will like another, the most powerful and the easiest to implement is similarity. In a simple but telling demonstration of the effects of similarity on influence, researchers mailed a set of surveys to random individuals. These surveys were accompanied by a cover letter, which for some of the recipients was "signed" by a researcher with a name designed to be similar to the recipient's. Although identical in all other aspects, the surveys sent with similar names were completed twice as often as the others. If something as trivial as similarity of names can affect compliance with a request, imagine how much more compelling a meaningful commonality, such as a shared interest, group membership, or goal, might be. A mediator or negotiator should spend the time necessary to locate such parallels among relevant parties and bring them to the surface.

2. **The principle of authority.** People are more easily influenced by those they perceive to be legitimate authorities. This response makes great sense because legitimate authorities have typically attained their positions by virtue of greater knowledge or skill or experience in the matter at hand. But for all their specialized knowledge, these experts frequently act like novices in the domain of social influence by assuming that their expertise is self-evident. For instance, physical therapists at one hospital were concerned about their patients' compliance with their prescribed treatment plans. After being discharged from the hospital, many patients discontinued their therapy exercises, no matter how much the therapists stressed their importance. However, a simple intervention solved the problem. By hanging their numerous awards, diplomas, and certifications on the walls of their clinic, the therapists were able to raise compliance by 34 percent. In general, genuine authorities should establish their expertise before launching any influence attempt (e.g., in a letter of introduction). To be optimally persuasive, however, expertise is not enough; a communicator also must establish that he or she is a trustworthy source of information.
3. **The principle of scarcity.** The principle of scarcity means that items and opportunities become more desirable as they become less accessible. As a result, an effective Project Manager should never fail to describe the unique or otherwise unattainable advantages of any recommendation or offer. Moreover, research on the principle of scarcity has demonstrated that, in situations characterized by uncertainty, presenting these unique advantages as what stands to be lost by a failure to take action is more persuasive than emphasizing what stands to be gained by taking the action.

**See the light!**  
**The sooner you realize we are right,**  
**the sooner your life will get better!**

A bit over the top? Yes we know!

We are just that sure that we can make your media activities more effective.



Get "Bookboon's Free Media Advice"  
 Email [kbm@bookboon.com](mailto:kbm@bookboon.com)



CREDIT SUISSE

DAIMLER



Microsoft

bookboon.com



4. **The principle of consistency.** People have a strong desire to be consistent with their previous opinions, assertions, and actions. Consistency can be used quite effectively when setting rules for people to follow. The key is to prompt them to make an initial public commitment that is consistent with the rule. Written commitments to a desired form of action are particularly effective in this regard, especially when the written commitment is then shown to others. In one study, participants were somewhat more likely to stay loyal to their initial decisions if they wrote down the decisions privately. But they were far more likely to remain loyal to those decisions if they wrote them down and then showed them to others. In general, research indicates that individuals are likely to live up to commitments that are active, public, and voluntary.
5. **The principle of reciprocity.** People give back what another has given them. Although reciprocity is usually thought of as governing the exchange of money, goods, or services, it does not apply only to the material or monetary. When participating in a conversation or discussion, by providing others with attention, information, concessions, and respect, you will likely receive the same from them in return.
6. **The principle of social proof.** One fundamental way that individuals decide what they should do in a situation is to look at what similar people have done. Hence, the “proof” of what is correct isn’t grounded in the physical environment but in the social environment: “If a lot of people like me are doing it, it must be the right thing to do.” This tendency to look to and follow the lead of similar others will be strongest in situations characterized by uncertainty. For instance, have you noticed how frequently we look to our colleagues and co-workers to determine how we should behave in a new setting? To the extent that these individuals demonstrate effective skills, techniques, or other productive behaviours, we are likely to do so too.

**Using the principles wisely.** Although the six principles can be treated separately, they should not be employed separately. They are best applied in combinations and strings that multiply their impact. Effective practitioners will be aware of influence opportunities that allow the principles to be employed conjointly or sequentially. Also, the science of social influence can be commissioned for good or ill. One needs to understand the acceptable versus the objectionable use of the process. Just because we can employ the lessons of that science to influence others doesn’t mean that we are entitled, or even wise, to do so. Using these principles to trick or trap others into assent has significant ethical and practical downsides. As the best influence professionals have long realized, to the extent that dishonest or high-pressure tactics work at all, they work only in the short run. Their long-term effects are malignant—undermining trust and damaging the reputation of the practitioner who employs them. Yet the same principles, if engaged appropriately, can influence decisions in a positive way. When the similarities are authentic, the windows of opportunity truly closing, the authority legitimate, the commitments freely made, the obligations genuine, and the social proof real, the resultant choices are likely to benefit everyone.

**Success Factor:** There is no right or wrong way to influence. It is however critical that you think about what to do and how to do it, when working with other people.

## Bøger til forandring og vækst

Forlaget Birmar har i over 10 år udgivet bøger, som er kendetegnet ved at være direkte anvendelige i udviklingen af virksomhed og organisation, ledelse og personlig udvikling. Blandt nyhederne er:

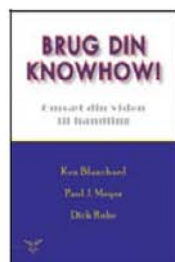

Se alle vores bøger på [www.birmar.dk](http://www.birmar.dk)

Her kan de også købes i det fulde omfang.

Se alle vores bøger på [www.birmar.dk](http://www.birmar.dk) – her kan de også købes i det fulde omfang.

**Nyhed fra forlaget:**

**BOG + FOREDRAG = MERVÆRDI**

Forlaget Birmar A/S  
Strandmøllevej 2  
6000 Kolding  
Tlf.: 75 50 15 29  
Fax: 75 53 36 60

FORLAGET  
**BIRMAR**



# 5 Control and Report

The Control and Report process step should be happening throughout the execution phase. As you execute and deliver your project, you should be controlling that the project is not deviating from the plans, and you should be communicating out to your stakeholders.

Project Control takes place constantly throughout the execution phase. It is iterative, and should be done routinely and often. The longer you wait to control the status of your project, the more time the project has to get off-track, and the more time it will take to get the project back on track again (if ever!)

Think of yourself as a lighthouse, with a 360 degree view. You need to be aware of all areas of the project so that any risk of deviation can be seen BEFORE it happens. This gives you time to do something to avoid it.

**Outputs** of this phase are:

**Confirmation of completion** – a work package has been completed, and is accepted by the customer and/or sponsor, or the project has been completed.

**Rework** – if the work package was not completed as we expected, then it may be necessary to re-do the work. This adds time to the project, and delays.

Project Control is one of the most visible jobs that a Project Manager does during the Execution phase. In fact, when you are wearing your Project Manager hat (as opposed to your “expert” or “doer” hats) then you should be spending up to 80% of your time controlling the project.

Controlling means coordinating, communicating, listening, checking, and confirming:

- Quality
- Risks
- Issues
- Costs
- Schedule

You should show a balance of leadership and management, since you will be controlling the work that your team members are doing.

It is a balance of technical and people skills since you need to know what your team members are doing (without necessarily being an expert), and also to keep them motivated and happy working in your team.

The more you are able to identify problems coming before they happen, the more time you have to avoid the problems and keep the project on track. If you can stay pro-active, you will spend less time fire fighting and more time managing the project.

**Success Factor:** You need to be aware of all areas of the project so that change can be seen BEFORE it happens. This gives you time to do something to avoid it.

## 5.1 Communication

Communication is the oil that helps the wheels of a project – and of any organisation – turn smoothly. We never communicate enough, and rarely do we communicate as consistently as we ought to. The problem with communication is that everyone does it – more or less well – and we all expect and assume that the messages get through.

The problem is that there are many barriers (filters) in the communication process:

- Semantic Problems
- Absence of feedback
- Improper channels
- Physical distractions
- Status effects
- Cultural differences

Effective communication is critical to the success of the project. Communication not only provides stakeholders with key information and milestones, it also creates a dialogue among stakeholders, surfacing pockets of resistance and building commitment to the project. When the level of change to the organization increases as a result of the implementation of a standard system, the amount and depth of communication must also increase.

Within this context, the term Communications includes:

- Providing factual information
- Requesting information or contributions from key individuals
- Offering viewpoints and opinions

- Seeking clarification, raising issues or asking straight forward questions
- Providing information, comments or suggestions as requested
- Seeking public support and commitment from key people and stakeholders

Communications should include speaking opportunities for managers, informal communications, face-to-face discussions, scheduled meetings and orchestration of senior management and “ad-hoc” communications as well as formal methods such as memos, notice-boards, E-Mail and newsletters.

A communication plan should both be a dynamic document used for the management and control of planned communications and also as a vehicle for leveraging benefits from unplanned but equally important events. The management of such events is eased by clarity of understanding as to the progress of the project as a whole, the difficulties being encountered and the steps being taken to address such issues. The stronger and more robust the communications base, the greater the chance to secure a clarity of purpose and a common understanding of progress within a project such as this.



**VI KUNNE IKKE DRØMME  
OM AT SINKE DIG  
OG DIN KARRIERE...**

*www.mh.dk*

**Merkonomernes  
Hovedorganisation**

*Vi er til for dig – og du bestemmer tempoet!*

Merkonomernes Hovedorganisation er en landsdækkende faglig organisation – med egen A-kasse for Merkonomer, AkademiMerkonomer, Agrarøkonomer, studerende og andre med tilsvarende uddannelser.



Feedback and monitoring of communication is key to the whole process as this makes the activity a two-way process whereby questions can be raised and answered rather than a one-way “tell them” approach. It is essential to ensure that the reality of the communications strategy being two-way is demonstrated on a regular basis by responding efficiently to questions and suggestions publicly and by using an interactive tool such as the intranet. Monitoring of communications is important to assess whether the messages intended are actually being received by the workforce and other key stakeholder groups. The communications process needs to be sufficiently flexible to adapt to the changing needs of either the sources or the receivers of information. This is particularly the case with this project where there will be a need to communicate across and within departments.

This communication plan includes the infrastructure for the dissemination of information throughout the departments involved; the allocated responsibilities and the expected timetable of events.

This communication plan is a living document and as such will evolve over time and is made up of a number of key outputs which together form a detailed communications plan :

1. Communication Goals
2. Communication Strategy
3. People Involved
4. Themes, Messages and Information
5. Communication Channels
6. Roles and Responsibilities
7. Key Success Factors

#### 5.1.1 Communication Goals

The communication goals for the project are:

1. **To build *awareness* among all employees about the project**
  - the business case (Why now?)
  - scope and high-level timeline
  - impact and value to the organisation
  - integration with other existing initiatives
2. **To build *understanding* among key Sponsors and Senior Management about the project, setting the stage for commitment to expected changes.**



3. The typical commitment curve : (Note that at each point there is the risk of failure)

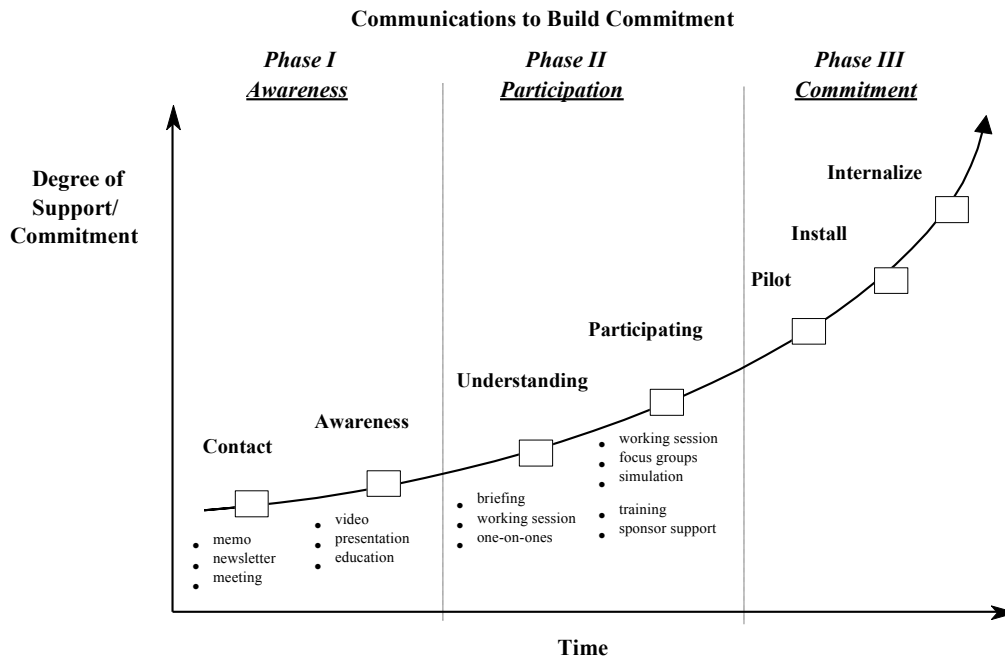

**Figure 22:** The Typical Commitment Curve

### 5.1.2 Communication STRATEGY

The reason for the communications element of a project is to enhance the overall success of the project; it is not communication for communication's sake. Nor is it going through the motions of informing people because that is the normal thing to do. Instead it is a fundamental enabler in the change process and the prime method for gaining commitment from essential stakeholders and sponsors to the initiatives. For this reason a number of objectives have been established that extend beyond merely formal communications.

The communications strategy objectives include:

- To demonstrate effective and consistent leadership of change within the project and within the organisation which includes personal commitment from senior people in their roles as Leaders of change.
- Ensure that everyone who needs to know about the progress of the project and its aims are clearly and effectively communicated with at the appropriate time.
- Ensure that key project communication events requiring support from the organization are briefed in time to allow a full commitment from those designated to attend.
- Assist in the formulation and organisation of key messages due for release to the business at such key events.
- Assist in the management and moderation of the methods of delivery for all key messages.

- Provide templates to ensure all messages emanating from the project are communicated in a consistent and professional manner.
- Ensure key messages assist in building support in the organization for the proposed process changes and generate enthusiasm for their implementation.
- Ensure all feedback received, verbal or otherwise, is captured and linked to the ongoing project process.
- To leverage the benefits of effective regular communication between the Project Team and the Line Managers.
- To provide early and effective responses to inaccurate and potentially damaging rumours from whatever source.
- To inform key audiences what needs to be achieved, by when and by whom and with what support.
- To inform people of the project's progress including successes and problems.
- To provide feedback mechanisms to allow interested stakeholders to ask questions or to make suggestions about the projects and to raise issues that are important to them.
- To limit any disruption to normal operations by ensuring a clarity of understanding as to what will be expected of people, when and to what purpose or ends.
- To assess and monitor the effectiveness of project communications.

## Hvor mange skal tage en beslutning, før man kan føre en beslutning ud i livet?



Slip for komplekse kommandoveje. Hos NNIT løser vi de store it-opgaver i små teams, der ikke skal spørge om lov til at tage en beslutning. Se ledige job på [nnit.dk/job](http://nnit.dk/job)

**nnit**

Conscience driven. Value adding



**In summary:**

To disseminate timely, honest and clear communications associated with the effective and efficient introduction and implementation of the new processes and system. By doing this, the plan will contribute significantly to securing the active continuation of the project by sustaining the support of key senior sponsors and Leaders of Change.

## 5.1.3 Communication Stakeholders

Department	Name	Role

**Figure 23:** Communication Stakeholders

## 5.1.4 Themes, Messages and Information

The following information should be regularly communicated according to the Communications timetable:

- scope and timeline
- key milestones, events, status, and accomplishments
- impact and value to the organisation and key stakeholders
- their role in the change process
- integration with other existing initiatives
- overview of the project

## 5.1.5 Operational Approach

The approach for the project communication is focused on breath of information for groups of employees and depth of information for key sponsors and influencers in the business. This should be accomplished by:

- Defining and communicating with a list of all key sponsors and key influencers in the organisation to an agreed timetable, using defined templates and clearly specified requirements

- Conducting an initial communications briefing with this group to:
  - Demonstrate the level of senior commitment to the project
  - Confirm the business case behind the project
  - Share the vision behind the project
  - Communicate the broader details of the project including participants, key stages, outputs and deadlines
  - Provide them with an opportunity to raise concerns, issues, ask questions and to offer their own views
  - Seek their ongoing support for the project and to demonstrate how this can be enacted
  - Seek their active involvement in the communication cascade from that point onwards
  - Explain the mechanics of how the communication strategy will operate
- Defining a process for the production and dissemination of appropriate briefing documents to be cascaded, via Senior Managers to their staff
- Defining an effective and efficient process by which contributions can be offered back into the project including questions, suggestions or responses to requests from the departments involved
- Creating a process for face-to-face dialogue among key sponsors of the Project Management process as a critical step because it allows stakeholders the opportunity to surface issues and questions as well as receive information about the project.



## 5.1.6 Communication Matrix

<b>Audience</b>	<b>Message</b>	<b>Communication Type</b>	<b>Frequency</b>	<b>Messenger / Medium</b>	<b>Primary Responsibility</b>
Sponsor	Project status Changes to people, processes, and technology Benefits of project Impact of the project on the organization Roles and responsibilities	Report Verbal and written	As needed (at least monthly)	Face-to-face and e-mail	Project Manager
Management	How the project's benefits can be leveraged to the rest of The Company	Report Verbal and written	As needed (at least monthly)	Face-to-face and e-mail	Project Manager
Project Team	Project status Changes to people, processes, and technology Project team needs Major project barriers and recommended solutions	Weekly update report (including summary) and meeting	Weekly	Written report (e-mail) and face-to-face	Project Manager
Future Users	Project activities and key decisions Resolution of issues that could not be handled by project team Major Milestones Roles and responsibilities Capabilities of new system	Meeting and written report  Live Demonstration / Day-in-the-life example	Weekly  Once	Face-to-face and written update (via e-mail)  Future State Design Session	Project Management
Other people concerned	How the department is changing (people, process, technology) Benefits of project Impact of the project on the organization Project objectives, scope, timings Project status Implementation plan impacts	Presentation and live-discussion / facilitation Written status reports	Twice (once at high-level early in the project life and once before training) Bi-monthly	Live session Information board E-mail, training catalogues	Project Management, Head of Department Communications leader

**Figure 24:** Communication Matrix

### 5.1.7 Roles and Responsibilities

#### **Communication Leader (or Project Manager)**

- Coordinate all communications
- Maintain standard information packages
- Modify communications where necessary
- Conduct communications activities/events
- Update Project Team on progress
- Manage communications plan and implementation and needed adjustments
- Prepare update/status communications
- Develop and customize communication media
- Produce communications
- Query field for communications effectiveness/appropriateness

#### **Department Representative**

- Conduct communication activities
- Modify communications where necessary
- Update Communications Leader/Project Manager on progress
- Query field for communications effectiveness/appropriateness

#### **Administrative Assistant (when necessary)**

- Maintain database of matrices, constituency groups, addresses
- Maintain central files of communication documents
- Set up logistics of communication activities
- Maintain checklist of who has to review/sign-off before communication gets delivered

### 5.1.8 Key Success factors

Factors impacting the success of communication include ensuring that:

- A consistent message is delivered to all concerned at the right time
- Sponsorship for the project is cascaded throughout the organization
- The organisation's employees understand the need for change
- Employees involved progress up the Commitment Curve at an appropriate rate
- Key people input their perspective and understand their role in the project and the future
- Key people are kept updated on project progress
- Communications are efficient and effective and make maximum use of existing communications media
- Communications influence behaviour

**Success Factor:** Communication is the life blood of any project or organisation. However bad or un-coordinated communication can be worse than no communication.

## 5.2 Listening

When we communicate, we tend to assume that this is when we are doing the talking. In fact, a Project Manager needs to spend more time listening than talking.

If you want to learn something, you need to listen.

If you want to be perceived as a good communicator, you need to listen.

If you want to avoid people resisting the changes, you need to listen to them.

Listening is a skill and it takes practice to listen actively. For those who spend more time talking than listening, it can be very tiring. It is however very rewarding.



The advertisement features the Widex logo at the top right, with the tagline 'HIGH DEFINITION HEARING'. The main headline is 'SÆT LYD PÅ FREMTIDEN' in large blue letters. Below this, there are four paragraphs of text in Danish, followed by a call to action. A dotted line graphic curves from the headline down to a pair of blue and white hearing aids. The website 'www.widex.com' is printed at the bottom right of the ad.

**WIDEX**  
HIGH DEFINITION HEARING

## SÆT LYD PÅ FREMTIDEN

Widex udvikler højteknologiske høreapparater til gavn for de 500 millioner mennesker verden over, der har nedsat hørelse.

Mere end fem årtiers intensiv forskning og udvikling har gjort os til en af verdens førende høreapparatproducenter, og vi udvikler digital teknologi af en kvalitet, kun få kan måle sig med.

Som videnbaseret virksomhed betragter vi medarbejderne som vores vigtigste kapital. Vi kan godt lide at gøre tingene selv og sætter en ære i at være selvforsynende inden for de fleste områder. Det skaber et spændende, tværfagligt arbejdsmiljø med plads til initiativ og rig mulighed for personlig og faglig udvikling.

Vil du være med til at sætte lyd på fremtiden?  
Følg med i vores jobopslag på [www.widex.dk/job](http://www.widex.dk/job)  
eller skriv til [jobbox@widex.com](mailto:jobbox@widex.com)

[www.widex.com](http://www.widex.com)



### 5.2.1 Ten Steps to Good Listening

1. Stop talking
2. Put the other person at ease
3. Show that you want to listen
4. Remove any potential distractions
5. Empathise with the other person
6. Don't respond too quickly – be patient
7. Go easy on argument and criticism
8. Ask questions
9. Rephrase key points
10. Stop talking (never too late)

## 5.3 Reporting

What is in a good management progress report?

- Tasks on Critical Path achieved this week
- Tasks on Critical Path that are late this week
- Changes to the Critical Path
- Other Tasks achieved this week
- Other Tasks late this week
- Milestones achieved this week
- Planned tasks for next week
- High level issues and their resolution plans
- High level risks and their resolution plans

When we speak about communication in projects, we are also talking about Progress Reports.

These reports are crucial to the success of the project because your stakeholders need to know what is happening, how the project is going, whether there are any problems or risks, and whether the project is still on track.

A common mistake new Project Managers make is to hide unpleasant facts, and only communicate the good news.

The bad news will not go away. It will only get worse if we ignore it.

If we have a problem or need help, it is better to ask for help as soon as possible, before the problem gets bigger and it will be too late.



**Note:** We provide information on what matters: the **Critical Path**

Keep the reports simple, colourful, with easy to read graphs and charts, and bullet points.

**Success Factor:** You can manage what you focus on. Changes to the Critical Path are the most important elements to focus on in order to ensure project success.

**An Example of a Weekly Status Report**

	<b>Week ending</b>			
	<b>Project Manager</b>			
	<b>Sponsor</b>			
<b>Summary of project objectives</b>				
<b>Start date</b>				
<b>End date</b>				
<b>Work on the Critical Path completed this week (activities or deliverables)</b>				
<b>Deliverable/activity</b>	<b>Sign-off by</b>	<b>Planned date</b>	<b>Actual date</b>	<b>Comment</b>
<b>Work on the Critical Path planned and not completed this week (activities or deliverables)</b>				
<b>Deliverable/activity</b>	<b>Sign-off by</b>	<b>Planned date</b>	<b>Actual date</b>	<b>Comment</b>
<b>Work off the Critical Path completed this week (activities or deliverables)</b>				
<b>Deliverable/activity</b>	<b>Sign-off by</b>	<b>Planned date</b>	<b>Forecast date</b>	<b>Comment</b>
<b>Work off the Critical Path planned and not completed this week (activities or deliverables)</b>				
<b>Deliverable/activity</b>	<b>Sign-off by</b>	<b>Planned date</b>	<b>Forecast date</b>	<b>Comment</b>

Work for next week (activities or deliverables)								
Deliverable/activity	Critical Path?	Sign-off by	Planned date	Comment				

High Level Risks								
Risk Number	Description	Owner	Probability	Impact	Status	Counter Measures	Contingency Actions	Budget

High Level Changes								
Change Number	Description	Owner	Assessment Result	Action Description	Approved By	Estimated Start	Action result Description	Date finalised

Commentary and issues requiring resolution								

Figure 25: Weekly Status Report Example

# Do you know Schneider Electric?

We are a global specialist in energy management represented in more than 100 countries. We provide technology and integrated solutions to optimise energy usage across multiple market segments. We are more than 130,000 colleagues worldwide and 1.000 of us are situated in Denmark.

We invest in our employees, in the environment and in the future. Each year 5% of our revenue is allocated for research and development activities. In Schneider Electric you have many career paths to choose from – also internationally.

Would you like take on the challenge of transforming the way people and organisations use energy?



Meet us at:  
[www.schneider-electric.dk/job](http://www.schneider-electric.dk/job)





## 5.4 Managing Delays

### How to decide when to start a task?

- Is the start dependent on any previous tasks?
- Has the last task been completed?
- Is the staff available to work on the task?
- Start the task as early as possible (without affecting later tasks)

Do NOT wait to start a task that can already be started, just because the task is scheduled for a certain date.

### Be PROACTIVE

### What to do if you see you will be late?

- Assess the impact on cost, schedule, quality and risk
- Take action to reduce or eliminate delay
  - Add or change people
  - Reduce scope
  - Do tasks in parallel rather than in series
- Accept the delay and change the project end date (and get agreement from Sponsor/Client)

**Success Factor:** If you start a project late, or accept too short a time to complete it then do not be surprised if the project is late.

## 5.5 Escalation

In some companies, escalation is seen as a weakness. This is counterproductive. Escalation is natural, and it is the job of the Sponsor of the project to solve problems and/or remove obstacles that the Project Managers cannot do themselves.

It is important for the Project Manager to define the escalation process at the beginning of the project, and to make sure that the Sponsor is aware of the process and of what they will be asked to do in case of escalation.

This should happen during the first meeting between the Project Manager and the Sponsor. They should define what the Sponsor can expect from the Project Manager and what the Project Manager expects from the Sponsor to ensure a successful project.

In other words, how can the Sponsor best help the project succeed?

## 5.6 Negotiating Rational Delays

Very often, we see projects that have deadlines that are impossible to meet.

When this is the case, the Project Manager needs to stand up for the project and for reality. He needs to be able to negotiate rational schedules, based on facts and figures, and based on the Triple Constraints as well as the other parameters listed above.

New Project Managers have a tendency to say yes to everything. This is dangerous, since there may be valid reasons for a longer deadline, and the consequences of accepting irrational deadlines will be a “failed” project.

Remember the 4 most useful words in a Project Manager’s vocabulary:

### YES, BUT and NO, BECAUSE

**Success Factor:** Base your discussion on facts and numbers. Use the Competing Constraints Diagram. Use risks and consequences. Do not commit when you know you cannot achieve the delay.

## 5.7 Team Meetings

As Project Manager, your job is to coordinate the work that the team does. In order to be able to do this efficiently, the best is to meet regularly with the team (either physically or virtually) to discuss the project status, the problems that have occurred, possible delays and risks, and just make sure that all the team members are aware of what is happening in the project.

### Weekly Meeting Checklist

- Last week’s events
- Next week’s events
- Critical Path – has it changed? Are we on track?
- Existing risks – actions taken?
- New risks?
- New Change Requests
- Lessons learned from the last week?
- Issues list

## 6 Project or Phase Close

The Close phase of a project is just as important as the other phases.

The results of the Close phase are:

- **Formal acceptance by sponsor / client**
  - Outstanding items closed
  - Client sign-off documentation

The best way to ensure that you get formal acceptance or sign-off is to ask for sign-off throughout the project. Every time you have achieved a certain milestone and group of Work Packages, ask for sign off. This ensures that:

- You remain on track
- The Customer / Sponsor is kept informed of progress
- The Customer/ Sponsor has a chance to tell you if you are going off track
- It is easier to get the final sign-off at the end of the project



**HD – vejen til  
en karriere  
i erhvervslivet**

**LÆS HD I ØKONOMI OG LEDELSE**

HD er en anerkendt diplom-uddannelse, som giver dig mulighed for at specialisere dig inden for det erhvervsøkonomiske fagområde ved siden af dit job.

**Læs mere**  
Aarhus: [hd.au.dk](http://hd.au.dk)  
Herning: [auhe.au.dk/hd](http://auhe.au.dk/hd)



- **Support organizations**
  - Staff evaluations completed
  - Budget reports completed
  
- **Close Supplier contracts**
  - Evaluate results
  - Payments completed
  - Signoff documentation for Suppliers
  
- **Lessons learned**
  - Internal/external review meetings
  - Identify variances to baseline plans and corrective actions
  - Review risk management results
  - Categorize positive and negative results
  - Document

**Success Factor:** Identify the lessons learned throughout the project at every team meeting, and not just at the end. This allows you to use the learnings in the current project.

- **Celebrate the project close**

Celebration does not have to be expensive or a big party. It can be a pizza with the team, a glass of something on a Friday afternoon, or someone brings in cakes and cookies.

It is important to do because:

- The team members feel that the project has a clear end
- Motivation will be stronger for the next project
- We get to celebrate our team
- It allows people to move on, psychologically

So, just to remind you of the Project Process again:

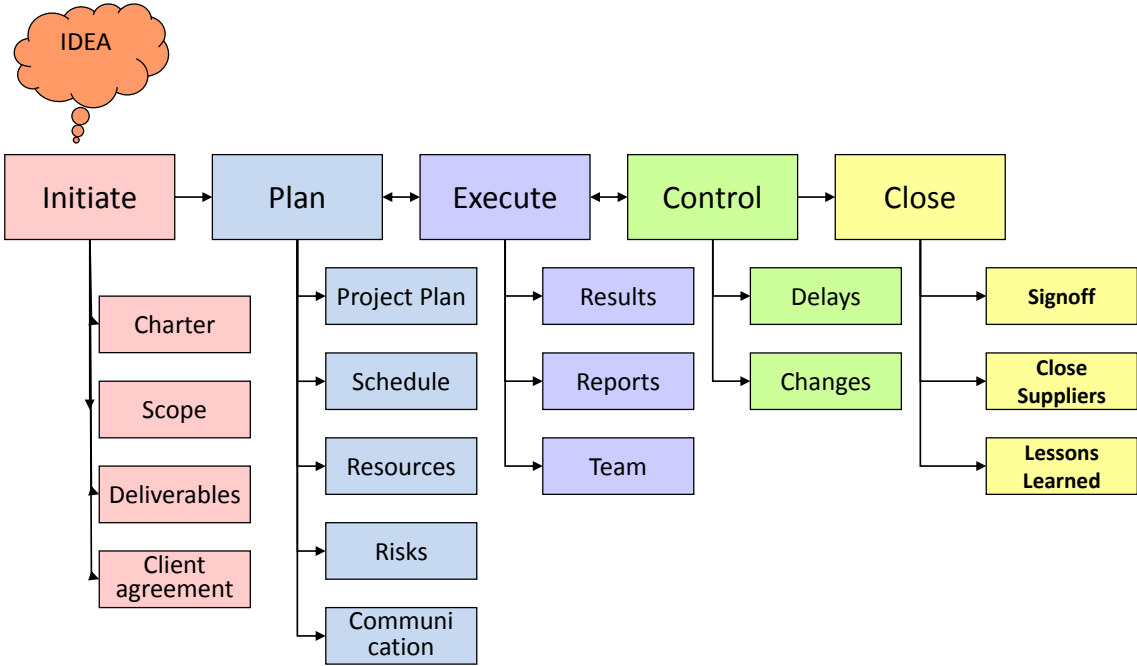

Figure 26: Project Process

Good Luck!

## 7 References

Project Management Institute – PMI®

Project Management body of Knowledge – PMBOK®

The Five Stages of Project Team Development, Gina Abudi

The One Minute Manager Builds High Performing Teams, Ken Blanchard and Eunice Parisi-Carew  
Management Teams. M. Belbin (1981)

Coaching Across Cultures, Philippe Rosinski

Culture's Consequences: comparing values, behaviors, institutions, and organizations across nations,  
Geert Hofstede (2001)

Managing Change Across Corporate Cultures, Geerhard Trompenaars with Peter Prud'homme (2005)

101 Leadership Actions for Creating and Managing Virtual Teams, Ollie Malone

Managing at the Speed of Change , Daryl Conner

On Death and Dying, Elizabeth Kübler-Ross

Our Iceberg is Melting, John P. Kotter

The 6 Principles of Persuasion, Robert B. Cialdini, Roselle L. Wissler, and Nicholas J. Schweitzer

<http://www.kilmanndiagnostics.com>

# IFRS 2012

## – nu også som e-bog

IFRS 2012, Standarder og fortolkningsbidrag – på dansk fås nu både som trykt bog samt som e-bog til smartphone, tablet og pc.

Introduktionspris: e-bog og trykt bog kr. 1545,-

 E-bog inkl. opdateringer i 2012

Læs mere og køb e-bogen sammen med den trykte bog her: [shop.magnus.dk](http://shop.magnus.dk)

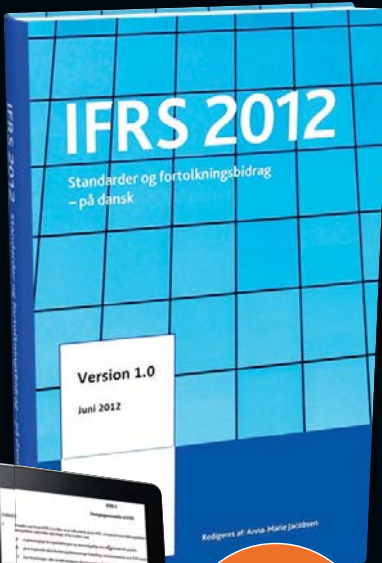

– Nu også som e-bog

## REGNSKAB

Magnus Informatik  
a Wolters Kluwer business

